

MIC-5604

Advanced Mezzanine Card based on Intel® Xeon® D Processors with DDR4 ECC

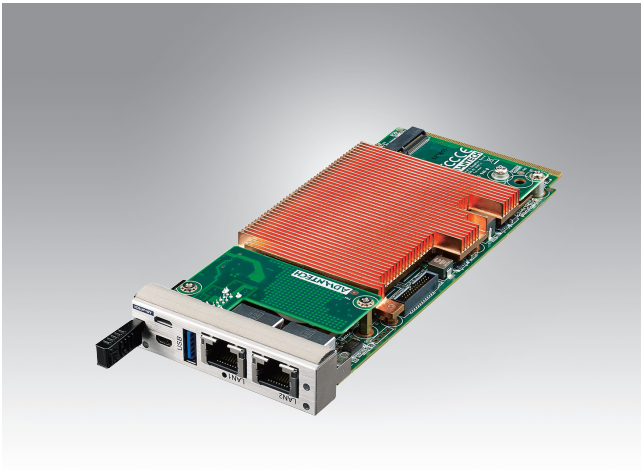

Features

- Supports Intel® Grangeville Platform Processor family
- Intel® Xeon®-D Soc
- Up to 8 GB / 16 GB (DDR4 1866/2133 MHz) soldered SDRAM with ECC
- Two Gigabit Ethernet (RJ-45), one USB 2.0/3.0, one console (micro-USB), and one HDMI Type D to front panel
- AMC connector routes Gigabit Ethernet (x2), SATA 3.0 (x2), PCIe x4
- Boot from network, onboard flash, M.2 SSD or external devices
- Supports IPMI v1.5 and Serial-over-LAN function
- AMC.0, AMC.1, AMC.2, and AMC.3 compliant



Introduction

The Advantech MIC-5604 is a single-width mid-size general purpose processor AMC module for ATCA or MicroTCA applications. Its design is based on Intel® Xeon®-D SoC processors in a BGA package. This AMC module supports processors with integrated memory controllers, and a maximum cache of 6MB. It can support up to 8/16 GB, dual-channel, on-board DDR4 memory with ECC at 2133/1866 MHz, making it ideal for mission critical applications requiring low latency and reliable memory access. For graphics or control applications the front panel HDMI port provides the Display support.

As standard feature, external Ethernet connectivity is provided on two dedicated GbE front panel ports, one each from the onboard Intel® I350 AM4 quad port LAN controller, which also provides two additional GbE ports to the AMC base fabric. The Intel® I350 supports remote management capabilities with KVM over LAN as well as introducing faster I/O than previous generation designs with SATA-III to AMC ports 2..3 and PCIe x4 gen.2 to ports 4..7. This module can also be configured to boot from the network, M.2 SSD, or external storage media such as HDD or USB drives.

To enable maximum application flexibility, the MIC-5604 is not only designed to support PICMG AMC sub-specifications such as AMC.1/2/3, it also has a fabric expansion mezzanine interface that allows the implementation of standard or customized mezzanine modules that offer enhanced fat pipe connectivity and I/O support. A dedicated Module Management Controller (MMC) monitors onboard conditions and manages hot swap operation, module replacement and field upgrades without the need to power down the carrier system.

Specifications

Processor System	CPU	Intel® Grangeville Platform Xeon®-D(Broadwell-DE) <ul style="list-style-type: none"> ▪ D-1508 Broadwell-DE 3MB 2c 2.2GHz 25W ▪ D-1527 Broadwell-DE 6MB 4c 2.2GHz 35W
	Max. Speed	2.2 GHz
	PCH	Integrated PCH
	BIOS	UEFI BIOS based on AMI (1. Redundant flash with HPM.1 update & rollback, 2. Configuration settings can be changed over IPMI)
Memory	Technology	Dual-channel DDR4 memory at 1867/2133 MHz soldered SDRAM with ECC
	Max. Capacity	8 GB / 16GB RAM (soldered on-board memory)
Ethernet	Controllers	Intel® I350-AM4 Quad-port Gigabit Ethernet controller
	Interface	Two GbE accessible on front panel via RJ-45 and two SerDes links to AMC ports 0 and 1
Front I/O Interface	Serial (COM)	One x86 Serial Port (USB slave connector through onboard USB to Serial converter)
	Ethernet	Two 10/100/1000BASE-T from Intel® I350
	USB 2.0/3.0	One port (Type A)
Mass Storage	M.2	Mezzanine Module with CFast socket (NOTE 1)
SATA		
Interfaces	AMC edge connector	Two SATA interfaces (6Gbps) to common option ports 2..3
	Other	One SATA routed to M.2 daughter board (optional)
Operating System	Compatibility	RHEL, CentOS, Windows Server 2008, Windows Server 2012
System Management	MMC	NXP LPC1768
	IPMI Compliancy	IPMI 1.5 with IPMI 2.0 features (e.g. RMCP, SOL) using Advantech IPMI Core
Watchdog Timer	Supervision	One MMC watchdog, One payload watchdog
	Interval	IPMI compliant
Miscellaneous	LEDs	x1 blue for hot swap, x1 red/amber for failure and OOS, x1 green for general purpose
Compliance	Standards	PICMG AMC.0, AMC.1, AMC.2, AMC.3, IPMI v1.5, HPM.1
Power Consumption	Configuration	Intel® Xeon®-D D-1508 + 8GB on-board DDR-4 memory
	TDP (Estimated)	40W max. (52W max with D-1527 35W CPU)

Block Diagram

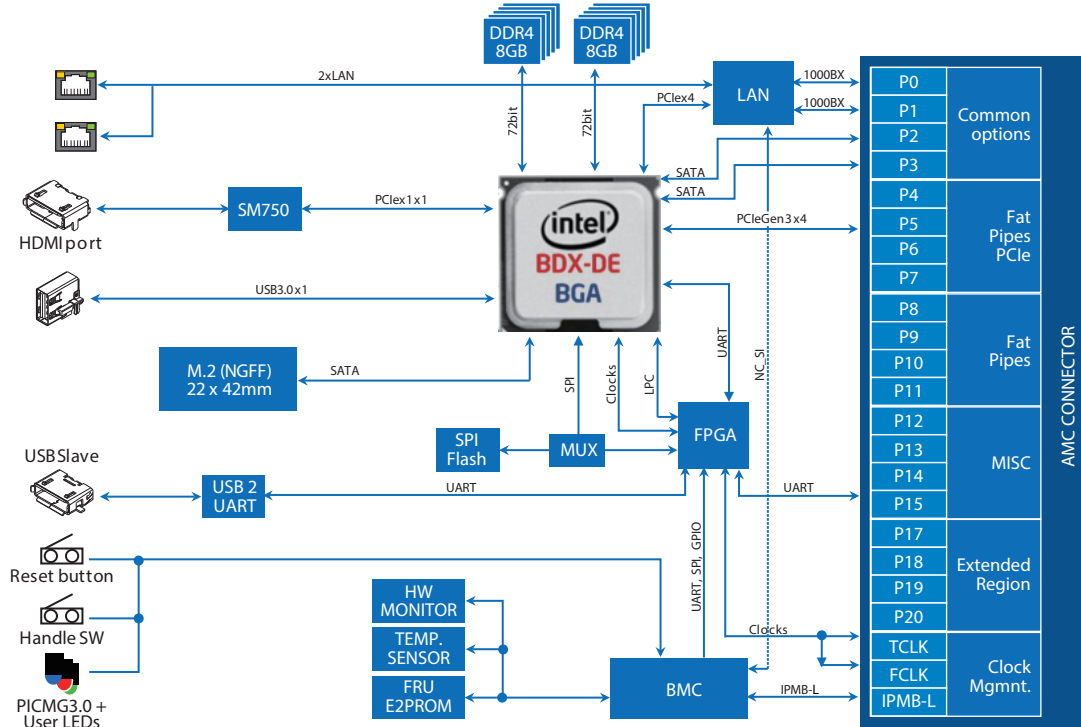

Specifications (Cont.)

Physical Characteristics	Dimensions (W x D)	Mid-size (or Full-size), 180.6 x 73.5 mm	
Environment	Temperature	Operating	Non-operating
	Humidity	-5 ~ 55° C (23 ~ 131° F) (NOTE 2)	-40 ~ 70° C (-40 ~ 158° F)
	Vibration (5 ~ 500Hz)	IEC60068-2-78 (95%RH @ 40° C)	
	Shock	IEC60068-2-6 (0.002G2/Hz, 1Grms)	
	Altitude	IEC60068-2-27 (10G, 11ms)	
Regulatory	Conformance	4,000m above sea level	10,000m above sea level
	Conformance	UL94V0, FCC Class B, CE, RoHS & WEEE Ready	

Ordering Information

Part Number (NOTE3, NOTE4)	Description
MIC-5604AM-S27-16E	With Intel® D-1527, Quad Cores, 2.2G ,35W CPU, 16G DDR4 memory, with M.2 daughter board but no M.2 Module
MIC-5604AM-S08-M8E	With Intel® D-1508, Dual Cores, 2.2G ,25W CPU, 8G DDR4 memory, with M.2 daughter board but no M.2 Module.

Where A stands for general AMC module option (M for Mid-Size, S= Standard).

Note:

1. M.2 module, available on the mid-size sku as default, and the AMC Mezzanine Module are mutually exclusive.
2. Operating Temperature: depending on the actual air flow through the AMC slot.
3. For lower or higher on-board memory support, please contact your local Advantech sales for options.
4. For the Intel® Xeon®-D CPU support, please contact your local Advantech sales.