

# AC 800M

## Controller Hardware

### Product Guide

System Version 5.1

Power and productivity  
for a better world™





# **AC 800M**

## **Controller Hardware Product Guide**

**System Version 5.1**

---

## NOTICE

This document contains information about one or more ABB products and may include a description of or a reference to one or more standards that may be generally relevant to the ABB products. The presence of any such description of a standard or reference to a standard is not a representation that all of the ABB products referenced in this document support all of the features of the described or referenced standard. In order to determine the specific features supported by a particular ABB product, the reader should consult the product specifications for the particular ABB product.

ABB may have one or more patents or pending patent applications protecting the intellectual property in the ABB products described in this document.

The information in this document is subject to change without notice and should not be construed as a commitment by ABB. ABB assumes no responsibility for any errors that may appear in this document.

In no event shall ABB be liable for direct, indirect, special, incidental or consequential damages of any nature or kind arising from the use of this document, nor shall ABB be liable for incidental or consequential damages arising from use of any software or hardware described in this document.

This document and parts thereof must not be reproduced or copied without written permission from ABB, and the contents thereof must not be imparted to a third party nor used for any unauthorized purpose.

The software or hardware described in this document is furnished under a license and may be used, copied, or disclosed only in accordance with the terms of such license. This product meets the requirements specified in EMC Directive 2004/108/EC and in Low Voltage Directive 2006/95/EC.

## TRADEMARKS

All rights to copyrights, registered trademarks, and trademarks reside with their respective owners.

Copyright © 2003-2013 by ABB.  
All rights reserved.

Release: February 2013  
Document number: 3BSE036352-510 A

---

# TABLE OF CONTENTS

## About This Book

General .....	13
Document Conventions .....	13
Warning, Caution, Information, and Tip Icons .....	13
Terminology.....	14
Applicable Specifications .....	15
EUROPEAN UNION DIRECTIVE COMPLIANCE.....	15
UL LISTING .....	15
TÜV Approval.....	15
Released User Manuals and Release Notes .....	16

## Section 1 - Overview

Introduction .....	17
Product Benefits .....	20
Features.....	21

## Section 2 - Functional Description

Processor Unit - General .....	23
PM8xx Unit (Except PM891) .....	24
PM891 Unit.....	26
Processor Unit - Redundancy .....	29
Communication .....	31
Battery Back-up.....	32
Power Supply.....	34
Powering from an External Source .....	35
I/O System .....	36

Drive System .....	44
Installation.....	49
Configuration .....	52

### **Section 3 - Software Components**

General.....	53
--------------	----

### **Section 4 - Hardware Components**

PM8xx Processor Unit - Single Configuration .....	55
PM891 Processor Unit - Single Configuration .....	58
Processor Unit - Redundant Configuration .....	60
PM8xx (Except PM891) .....	60
PM891 .....	61
CEX-Bus Interconnection Unit - BC810 and TP857 .....	63
SM810 and TP855.....	66
SM811 and TP868.....	68
Communication Interfaces .....	70
PROFIBUS DP Interface - CI851 and TP851.....	72
RS-232C Interface - CI853 and TP853.....	74
PROFIBUS DP Interface - CI854/CI854A and TP854.....	76
MasterBus 300 Interface - CI855 and TP853 .....	78
S100 I/O Interface - CI856 and TP856 .....	80
INSUM Interface - CI857 and TP853.....	82
DriveBus Interface - CI858 and TP858 .....	84
FOUNDATION Fieldbus High Speed Ethernet Interface - CI860 and TP860....	86
TRIO/Genius Remote I/O - CI862.....	88
Satt I/O - CI865.....	90
Modbus TCP Interface - CI867.....	92
IEC 61850 Interface - CI868.....	93
AF 100 Interface - CI869.....	94
PROFINET IO Interface - CI871 .....	96
EtherNet/IP Interface - CI873 .....	98
Battery Back-up .....	99

Power Supply Components - SD83x and SS832 .....	102
Mounting Rails .....	106
CEX-Bus Extension and Termination .....	107
ModuleBus Extension and Termination .....	110
RCU Link Cable and Termination .....	110
TB852 RCU Link Terminator Plug .....	110
TB853 RCU Control Link Terminator Plug .....	110
TK851 RCU Link Cable for PM86x .....	110
TK855 RCU Data Link Cable for PM891 .....	110
TK856 RCU Control Link Cable for PM891 .....	111

## Section 5 - Mechanical Design

Cabinet Design .....	113
Mounting Dimensions for Proper Ventilation .....	117

## Section 6 - Technical Data and Performance

General .....	119
Processor Unit - PM8xx and TP830 .....	119
Performance Data for PM851/PM856 and PM860 .....	119
Performance Data for PM851A/PM856A and PM860A .....	119
Performance Data for PM861/PM864/PM865/PM866 .....	119
Performance Data for PM891 .....	120
CEX-Bus Interconnection Unit - BC810 and TP857 .....	130
SM810 and TP855 .....	131
SM811 and TP855 .....	132
PROFIBUS DP Interface - CI851 and TP851 .....	133
RS-232C Interface - CI853 and TP853 .....	134
PROFIBUS DP Interface - CI854/CI854A and TP854 .....	135
MasterBus 300 Interface - CI855 and TP853 .....	136
S100 I/O Interface - CI856 and TP856 .....	137
INSUM Interface - CI857 and TP853 .....	138
DriveBus Interface - CI858 and TP858 .....	139
FOUNDATION Fieldbus High Speed Ethernet Interface - CI860 and TP860 .....	140

TRIO/Genius Interface CI862 .....	141
Satt I/O Interface CI865 .....	142
Modbus TCP Interface CI867 .....	143
IEC 61850 Interface CI868 .....	144
AF 100 Interface CI869.....	145
PROFINET IO Interface CI871 .....	146
EtherNet/IP Interface CI873.....	147
External Battery Back-up Unit - SB821.....	148
External Rechargeable Battery Back-up Unit - SB822.....	149
Power Supply Components .....	150
SD831, SD832, SD833, SD834.....	150
SS822, SS823.....	151
SS832 .....	153
DIN Rail and AI-profile .....	154
<b>Section 7 - Ordering</b>	
Ordering Procedure .....	155
Price List Structure.....	155
<b>Appendix A - Power Consumption</b>	
General .....	157
Current Consumption and Power Dissipation.....	158
Calculations .....	160
<b>Appendix B - Recommended Components</b>	
Recommended Components.....	161
<b>Appendix C - Directive Considerations</b>	
Electro-Magnetic Compatibility (EMC) .....	175
Low-Voltage Directive (LVD).....	175
<b>Appendix D - Standards</b>	
Hazardous Location Approval.....	177



## **Appendix E - Environmental Data**

Environmental Data for AC 800M Products .....	179
Climatic and Mechanical Environmental Conditions .....	180
CE Compliance .....	182
Electromagnetic Compatibility and Main Voltage Conditions .....	183
Installation Requirements.....	185
Laying Field Cables .....	185
Types of Field Cable .....	185
DIN-rail mounting.....	185
Lightning Protection.....	186
Inductive Load Suppression .....	186

## **INDEX**

Introduction .....	191
Revision History .....	191
Updates in Revision Index A.....	192



---

# Safety Summary



## **Electrostatic Sensitive Device**

Devices labeled with this symbol require special handling precautions as described in the installation section.

## **GENERAL WARNINGS**

### **Equipment Environment**

All components, whether in transportation, operation or storage, must be in a noncorrosive environment.

### **Electrical Shock Hazard During Maintenance**

Disconnect power or take precautions to insure that contact with energized parts is avoided when servicing.

## **SPECIFIC WARNINGS**

-50, -63 and Page 70: It is not allowed to manipulate CEX bus base plates in a powered and running system. Before changing or removing a base plate, all CEX modules on that segment must be removed.

Page 177: Explosion hazard - Substitution of components may impair suitability for Class I, Zone 2.

Page 177: Explosion hazard - Do not replace batteries unless the power has been switched off or the area is known to be non-hazardous.

Page 178: Explosion hazard - Do not disconnect equipment unless the power has been switched off or the area is known to be non-hazardous.

## **SPECIFIC CAUTIONS**

Page 13: This Product guide does not contain last-minute product information and updates which might affect functionality and/or performance. For information on late changes and restrictions, please refer to the Release Notes, Control Software for AC 800M (3BSE021377\*).

Page 54: Always check that the CPU and other hardware units have the correct firmware version, before installing them. If the CPU is empty, CPU firmware must be loaded via the COM4 port.

---

## Safety Summary

**SPECIFIC  
CAUTIONS  
(continued)**

Page 175: If you use other power supplies, except SD82X and SD83X, to provide the 24V d.c. for AC 800M it is required that they also are CE marked, UL listed and fulfill the LVD (SELV and PELV).

Page 176: The AC 800M modules are to be considered as open equipment, according to EN 61131-2 and UL508, and must be mounted in non-public localities.

---

# About This Book

## General

This Product Guide is primarily intended for sales representative within ABB. An additional user group may be internal ABB customers and important external customers, using the Product Guide as a complement to existing product information.



This Product guide does not contain last-minute product information and updates which might affect functionality and/or performance. For information on late changes and restrictions, please refer to the Release Notes, Control Software for AC 800M (3BSE021377\*).

## Document Conventions

Microsoft Windows conventions are normally used for the standard presentation of material when entering text, key sequences, prompts, messages, menu items, screen elements, etc.

## Warning, Caution, Information, and Tip Icons

This publication includes **Warning**, **Caution**, and **Information** where appropriate to point out safety related or other important information. It also includes **Tip** to point out useful hints to the reader. The corresponding symbols should be interpreted as follows:



Electrical warning icon indicates the presence of a hazard which could result in *electrical shock*.



Warning icon indicates the presence of a hazard which could result in *personal injury*.



Caution icon indicates important information or warning related to the concept discussed in the text. It might indicate the presence of a hazard which could result in *corruption of software or damage to equipment/property*.



Information icon alerts the reader to pertinent facts and conditions.



Tip icon indicates advice on, for example, how to design your project or how to use a certain function

Although **Warning** hazards are related to personal injury, and **Caution** hazards are associated with equipment or property damage, it should be understood that operation of damaged equipment could, under certain operational conditions, result in degraded process performance leading to personal injury or death. Therefore, **fully comply** with all **Warning** and **Caution** notices.

## Terminology

A complete and comprehensive list of terms is included in *System 800xA System Guide Functional Description (3BSE038018\*)*. The listing includes terms and definitions that apply to the 800xA System where the usage is different from commonly accepted industry standard definitions and definitions given in standard dictionaries such as Webster's Dictionary of Computer Terms.



## Applicable Specifications

### EUROPEAN UNION DIRECTIVE COMPLIANCE

Units mentioned in this document for which the product is marked with the  logo comply with the EMC Directive EMCD 2004/108/EC and the Low Voltage Directive LVD 2006/95/EC. See [Appendix C, Directive Considerations](#).

### UL LISTING

Units mentioned in this document are UL listed if the product is marked with the UL logo.

 indicates UL approval for the USA, and  for both Canada and the USA. The logo  indicates UL approval for Canada only.

The applied standard is UL508, Industrial Control Equipment. Units approved for use at hazardous locations also comply with the standard UL60079-15. To fulfill the UL requirements for hazardous locations, the instructions in [Appendix D, Standards](#) must be followed.

### TÜV Approval

Units mentioned in this document are TÜV qualified for IEC 61508 SIL2 or SIL3 if the product is marked with the TÜV  logo.

## Released User Manuals and Release Notes

A complete list of all User Manuals and Release Notes applicable to System 800xA is provided in *System 800xA Released User Manuals and Release Notes (3BUA000263\*)*.

*System 800xA Released User Manuals and Release Notes (3BUA000263\*)* is updated each time a document is updated or a new document is released. It is in pdf format and is provided in the following ways:

- Included on the documentation media provided with the system and published to ABB SolutionsBank when released as part of a major or minor release, Service Pack, Feature Pack, or System Revision.
- Published to ABB SolutionsBank when a User Manual or Release Note is updated in between any of the release cycles listed in the first bullet.



A product bulletin is published each time *System 800xA Released User Manuals and Release Notes (3BUA000263\*)* is updated and published to ABB SolutionsBank.



---

# Section 1 Overview

## Introduction

AC 800M can be defined as a hardware platform consisting of individual hardware units. AC 800M hardware platform can be programmed to perform multiple functions, depending on the specific unit configuration and operating system selected.

The hardware units which form the AC 800M Controller are:

- Processor units (including base plates)
- Communication interfaces for different protocols (including base plates)
- Power supply units, providing various power output levels
- Battery back-up unit
- For High Integrity systems control applications with AC 800M HI, special module SM810/SM811, is needed

Once configured, the AC 800M hardware platform effectively becomes the AC 800M Controller.

Equipped with the specified Control Software, the AC 800M Controller can be used for all kinds of process and industrial automation applications. With Control Software, the controller can act either as a stand alone process controller or as a controller, performing local control tasks, in a control network consisting of many interconnected computers.

The AC 800M Controller is delivered without firmware. To provide the controller with Control Software, it will first be necessary to load the firmware and create the application separately by using the Control Builder interface.

The AC 800M Controller consists of a selection of units mounted on horizontal DIN rails, as shown in [Figure 1](#) on page 18, which can, if required, be housed within an enclosure.

The majority of units consist of a base mounting plate and a removable cover, which are attached to each other by means of screws. The base plate, which is always mounted on the DIN rail, carries the majority of the connections to the processor, power supplies and communication interfaces, as well as to the external buses and systems.

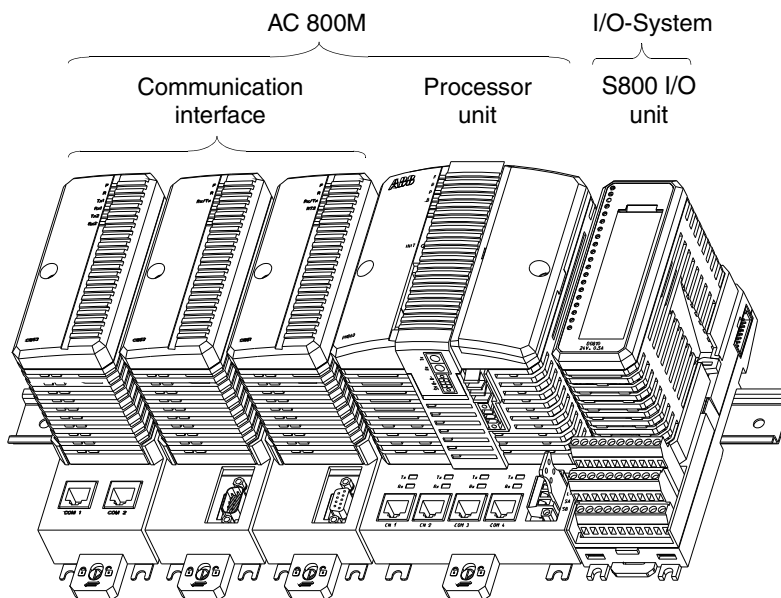

*Figure 1. Example of an AC 800M Controller with a S800 I/O Unit*

The processor unit used for the AC 800M HI Controller is physically identical to other AC 800M controllers, simplifying service and spares support and providing flexibility during the project build phase. The HI functionality is extended by the addition of a SM810/SM811 and the SIL certified software license only. This enables non-critical control schemes to be upgraded to SIL certified schemes by the addition of a plug-in SM810/SM811, plus selection of the appropriate license.

The basic unit for a AC 800M HI consists of PM865 and SM810/SM811, see [Figure 2](#).

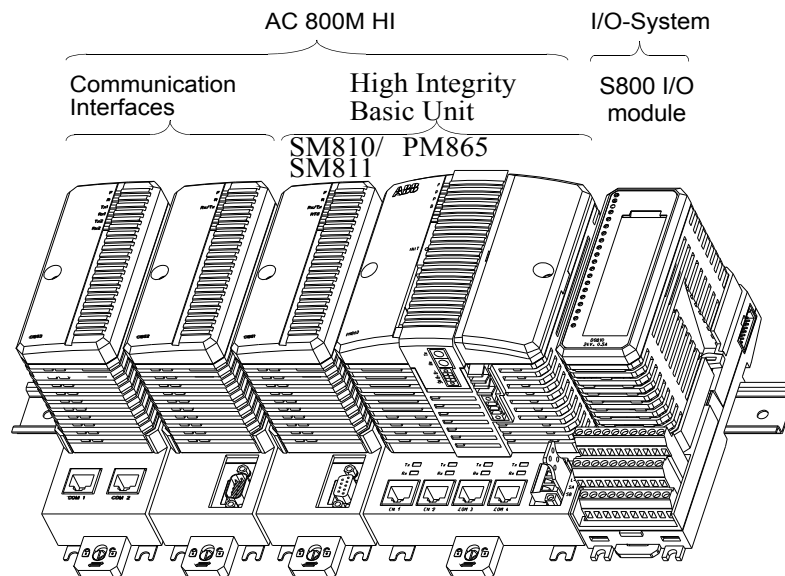

Figure 2. AC 800M HI

## Product Benefits

Some of the benefits of the AC 800M Controller are:

- Flexibility, the AC 800M Controller can be ordered as individual units which may be mounted in accordance with the customers own requirements.
- Extremely small footprint.
- Simple DIN rail attachment / detachment procedures, using the unique slide & lock mechanism.
- Modularity, allowing for step-by-step expansion. You only pay for what you require at the present time.
- Reliability and simple fault diagnosis procedures.
- Controller redundancy for higher availability (CPU, CEX-Bus, communication interfaces, S800 I/O).
- Built-in redundant Ethernet Communication ports.
- Built-in RS-232C communication ports.
- Low power consumption, thus no external fans required.
- Flexible process connection, using either local I/O or standard fieldbuses.
- S800 I/O redundancy.
- Supports S800 I/O High Integrity (with PM865 only).

## Features

The major features of the AC 800M are:

- High performance and large application memory.
- Extensive availability.
- CPU redundancy (PM861/PM864/PM865/PM866,PM891).
- AC 800M High Safety Integrity Level 2 certified using PM865/SM810/SM811.
- AC 800M High Safety Integrity Level 3 certified using PM865/SM811.
- Built-in redundant Ethernet channels.
- Built-in RS-232C channels.
- Sectioned CEX-Bus using a pair of BC810.
- Quick and simple fault-finding with the aid of LEDs on each unit / channel.
- Built-in battery back-up of memory (except for PM891).
- External battery back-up.
- Use of industry standard power supply voltage - 24V d.c.
- Easy mounting on standard DIN rail.
- IP20 Class protection without the requirement for enclosures.
- Incorporation of a wide variety of communication possibilities.
- Hardware based on standards for optimum communication connectivity (Ethernet, PROFIBUS DP).
- Support for PROFIBUS DP fieldbus.
- Support for FOUNDATION Fieldbus.
- Support for Advant Fieldbus 100.
- Support for Modbus TCP.
- Support for Field Device Tool (FDT) and Device Type Manager (DTM) concept for tool routing of HART instruments.
- Support for connection to INSUM via Gateway (Ethernet/LON).

- Support for IEC 61850.
- Support for PROFINET IO.
- Support for EtherNet/IP.
- Support for connection to S100 I/O.
- Support for connection to Satt I/O.
- Support for TRIO/Genius.
- Support for Genius remote I/O discrete, analog and high-speed counter blocks.
- Support for ABB Drives via PROFIBUS, ModuleBus and DriveBus.
- Support for connection to MasterBus 300.
- Full EMC certification.
- Selected units UL certified (UL508 as open equipment, and for hazardous locations according to UL60079-15 (Class 1 Zone 2)).

---

## Section 2 Functional Description

### Processor Unit - General



PM851 is equivalent to PM856 unless stated otherwise.

PM861A and PM864A are equivalent to PM861 and PM864 respectively, unless stated otherwise.

The processor unit (except PM891) consists of two parts:

- Processor unit, PM851/PM851A/PM856/PM856APM860/PM860A/PM861/PM861A/PM864/PM864A/PM865/PM866, equipped with power supply and CPU-boards



The PM865 processor unit is prepared for High Integrity applications. When used for non-High Integrity applications, it is equivalent to the PM864 processor unit.

- Base plate, TP830, with a unit termination board.

The PM891 processor unit is a monolithic unit equipped with power supply and CPU-boards, and unit termination.

The CPU board contains the microprocessor and the RAM-memory. The memory holds an executable version of the firmware, the controller system configuration and an application program.

The processor unit also has an optical ModuleBus used for connecting additional clusters of S800 I/O, and a connector housing for a plug-in backup media (Secure Digital card for PM891, and Compact Flash card for other processor units).

## PM8xx Unit (Except PM891)

The base plate of PM8xx unit (except PM891) has two RJ45 Ethernet ports (CN1, CN2) for connection to the Control Network, and two RJ45 serial ports (COM3, COM4). One of the serial ports (COM3) is an RS-232C port with modem control signals, whereas the other port (COM4) is isolated and used for the connection of a configuration tool.



Note that a PM851/PM851A is restricted to one Ethernet (CN1) port, thus redundant Ethernet is not available.

Both the electrical ModuleBus and the communication expansion bus (CEX-Bus) connectors are mounted on the base plate. The built-in electrical ModuleBus can be used in single CPU configuration for connecting one cluster of S800 I/O units directly to the base plate (maximum number of units per cluster is 12). However, an additional seven clusters (each comprising up to 12 units) can be added to the optical ModuleBus.



Note that no redundant modules are supported on the built-in electrical ModuleBus.

The CEX-Bus is used for extending the on-board communication ports with communication interface units. It is also possible to use redundant communication interfaces on the CEX-Bus. The CEX-Bus Interconnection unit BC810 is used to increase the availability on the CEX-Bus by dividing it into separate segments.

All base plates are provided with a unique Ethernet address which provides every CPU with a hardware identity. The address can be found on the Ethernet address label attached to the TP830 base plate, as shown in [Figure 3](#) on page 25.



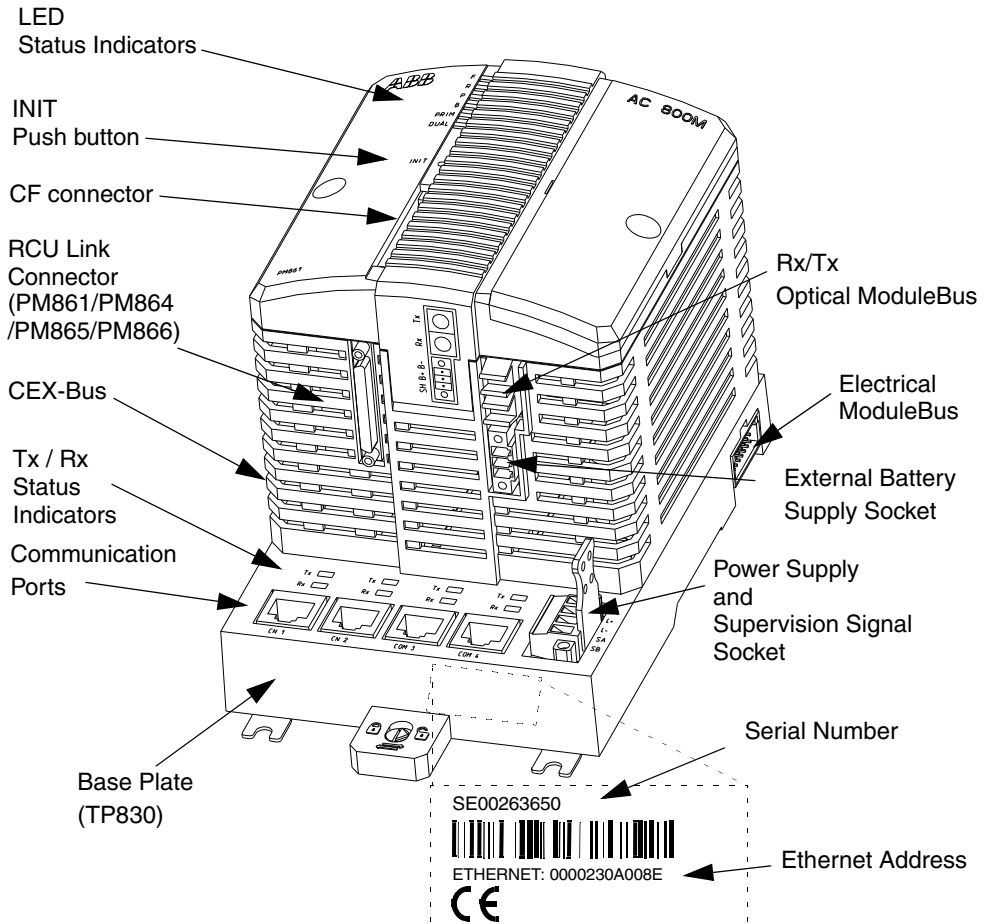

Figure 3. Processor Unit - General View (here shown with PM861 and TP830)

## PM891 Unit

The PM891 unit has two RJ45 Ethernet ports (CN1, CN2) for connection to the Control Network, and one RJ45 serial port (COM4). The COM4 port is isolated and is used for the connection of a configuration tool.

The communication expansion bus (CEX-Bus) is mounted on the unit.

The CEX-Bus is used for extending the on-board communication ports with communication interface units. It is also possible to use redundant communication interfaces on the CEX-Bus. The CEX-Bus Interconnection unit BC810 is used to increase the availability on the CEX-Bus by dividing it into separate segments.

The optical Modulebus at the bottom of the unit can be used for connecting seven clusters of S800 I/O units (each comprising up to 12 units).

Each PM891 unit is provided with a unique Ethernet address which provides hardware identity to the unit. The address can be found on the Ethernet address label located on the right-hand side of the unit.

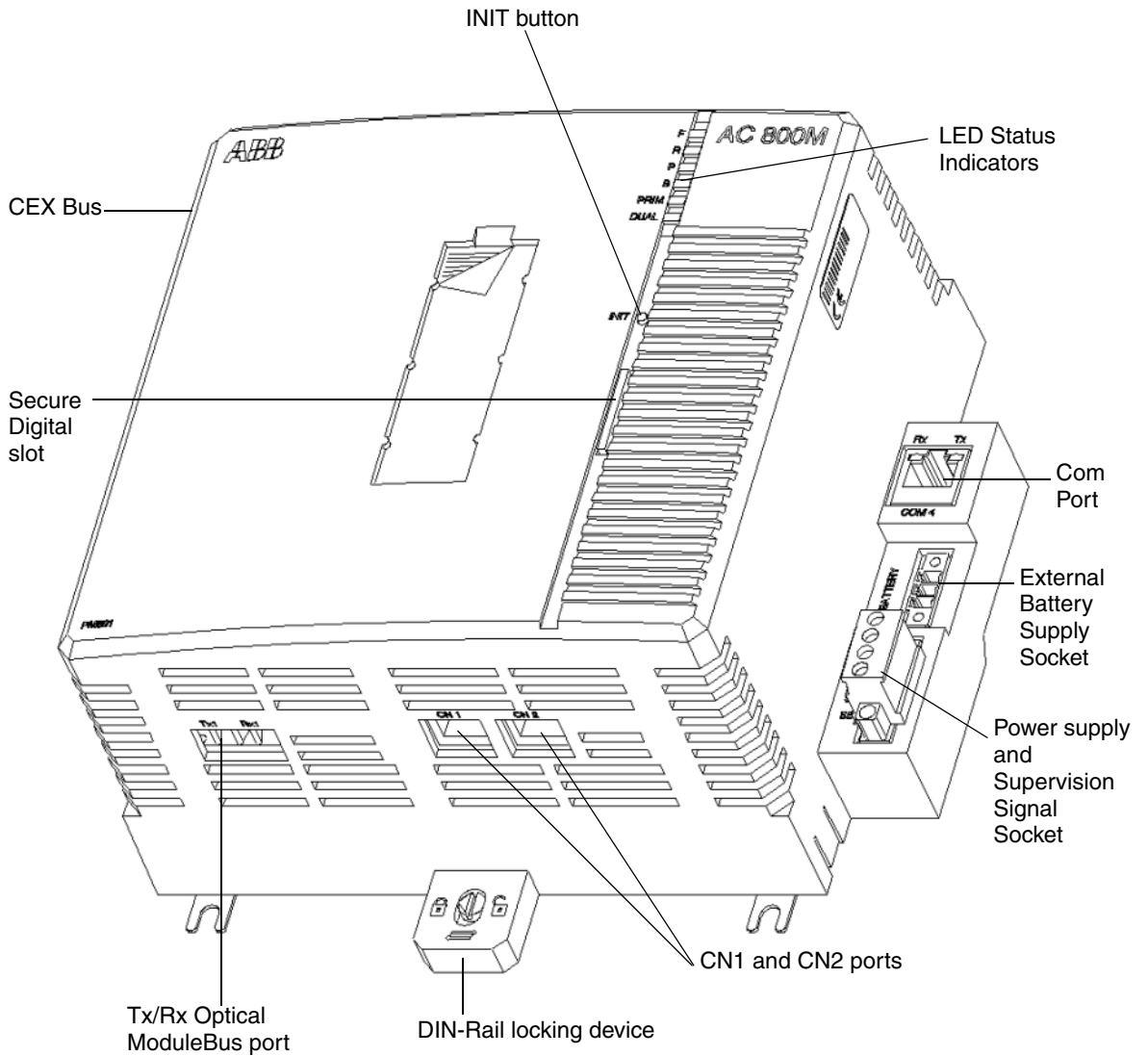

Figure 4. PM891- Front View

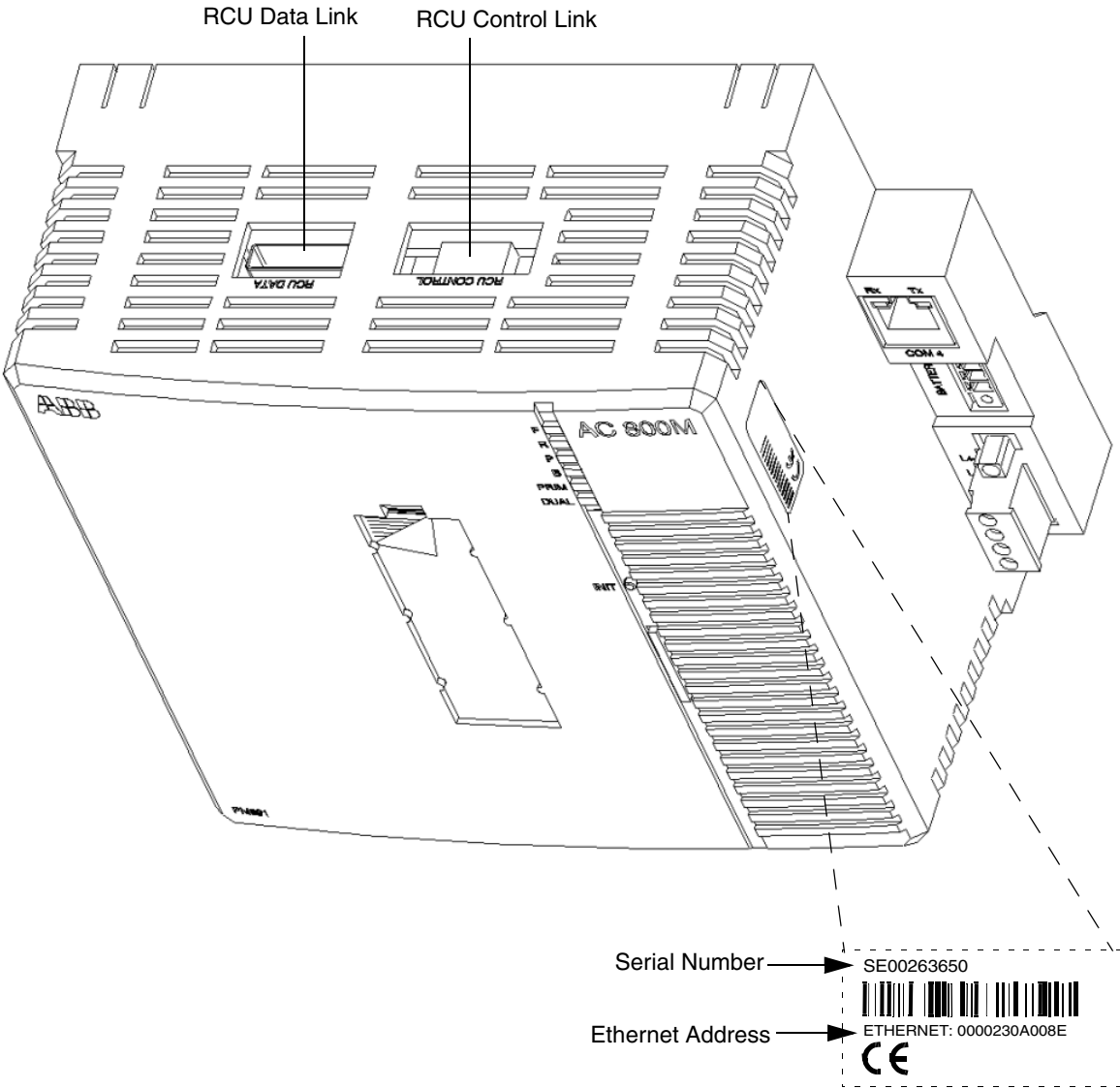

Figure 5. PM891- Top view

Table 1 shows the differences between PM891 and other PM8xx controllers.

Table 1. PM891 and other PM8xx controllers - Differences

Feature	PM8xx	PM891
CPU	MPC86x Microprocessors running between 48MHz to 133MHz	MPC8270 Microprocessor running at 450 MHz
TP830 Baseplate	Yes	No
Connection to S800 IO units	Electrical Modulebus and Optical Modulebus	Optical Modulebus only
Internal Battery	Yes	No
Redundancy Link	One RCU Link (only applies to PM861, PM864, PM865 and PM866)	RCU Control Link and RCU Data Link
COM3 port	Yes	No
Backup media	Compact Flash	Secure Digital
Replaceable internal fuse	Yes	No

## Processor Unit - Redundancy

Processor unit redundancy is available. In this case, the controller contains two processor units, each including memory for system and application software. One unit is acting as primary, the other is backup (hot stand-by). The primary processor unit controls the process. The backup stands by to take over in case of a fault in the primary. The changeover is done bumplessly and in less than 10 ms. During the changeover, the process outputs are frozen.

Following a changeover, the system operates as a system without redundancy with only one processor unit in operation. You can replace the malfunctioning processor unit while the system is running. After the replacement is carried out, the system once again has a redundant processor unit.

If an error arises in the backup unit, you can also replace the backup unit while the system is running.

Errors which occur in the backup unit can never affect the primary unit's operation. The primary unit and the backup unit are logically separated from one another. Hardware errors in the primary processor unit cause the system to perform a correct changeover. These hardware errors are "single errors".

The application programming and the communication are totally unaffected by the redundancy.



The serial port COM3, can not be used in redundant CPU configuration.



S800 I/O units are connected to the two CPUs by the optical ModuleBus. The built-in electrical ModuleBus on the base plates can not be used for connection of S800 I/O in redundant CPU configuration.

## Communication

The number of ports and protocols, provided by the processor unit, can be expanded by adding communication units to the CEX-Bus.

Examples of unit types that may be connected to the CEX-Bus are as follows:

- FOUNDATION Fieldbus High Speed Ethernet (FF HSE)
- PROFIBUS DP
- Dual RS-232C ports
- S100 I/O
- INSUM
- IEC 61850
- MasterBus 300
- Modbus TCP
- ABB Drives via DriveBus Interface
- TRIO/Genius
- Satt I/O via ControlNet (19" Satt rack I/O, S200 I/O and S200L I/O)
- AF 100
- PROFINET IO
- EtherNet/IP

This expansion provides the means of connecting remote I/O, fieldbus instruments and additional RS-232C ports.

## Battery Back-up

A battery is used to power the back-up for both the RAM and the real time clock in the case of a power failure. Battery back-up can be provided in two ways:

- using the internal battery (as shown in [Figure 6](#) on page 33). The internal battery is not available in PM891.
- using an external battery unit, (SB821), for longer back-up times.
- using an external rechargeable battery unit, (SB822), for longer back-up times.

The external battery unit is mounted on the DIN rail and connected to the CPU via a cable.



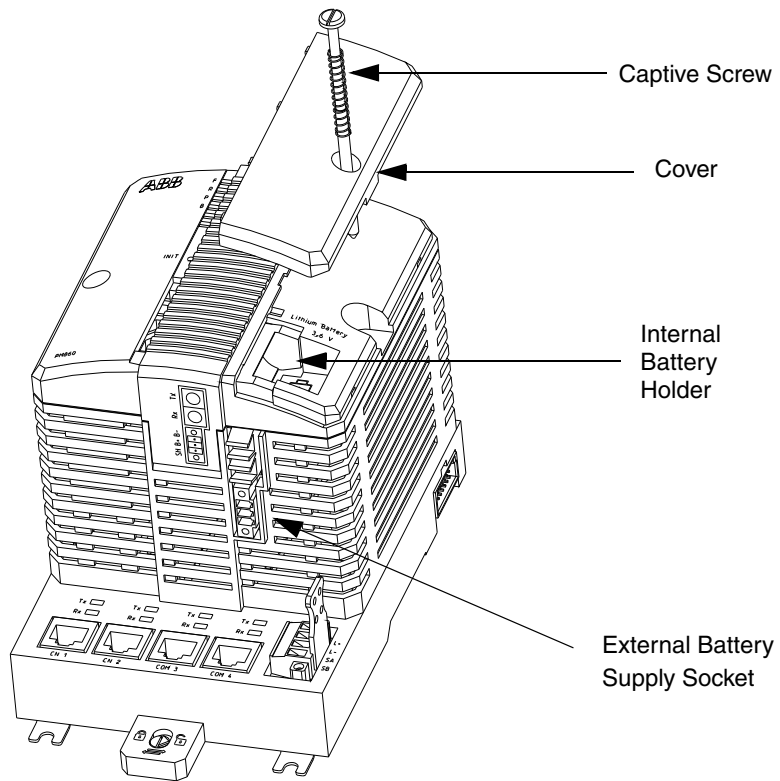

Figure 6. Back-up Battery - Connection

## Power Supply

The power supply units (SD83x) are switch-mode power converters that convert a.c. mains supply voltage to a regulated 24 V d.c. The mains input supply voltage can either be 115 V a.c. or 230 V a.c. and is selected using a switch, mounted on the front panel of the unit.

The power supply units can be used in both redundant and non-redundant applications. When redundant power supply units are connected to a common load, a voting device, (SS823), must be used to combine the two outputs to a single output, via diodes. The redundant power supply units may be connected to completely separate mains supplies or to the same mains supply, depending on the configuration selected.

The L- output (0 V) of the power supply units can be used without being grounded. If grounding is required, the power supply unit L- output (0 V) can be grounded directly or via a suitable resistor.

The processor unit has no requirement for an uninterruptible power supply in order to shut down safely. The processor unit has an internal power reservoir that lasts for 5 ms, which is sufficient for it to make a controlled power down. The power supply units easily handle short power interruptions (<20 ms) that can normally occur within any industrial environment. Despite this, it is sometimes necessary to protect certain applications, from brief voltage failures, by installing Uninterruptible Power Supply (UPS) devices.



For information on SD83x, refer to [Power Supply Units - SD831, SD832, SD833, and SD834](#) on page 102.

## Powering from an External Source

The AC 800M Controller can be powered from an external +24 V DC source. This source is often common for many different types of plant equipment, resulting in long power cables to the AC 800M Controller. Furthermore, heavy load changes can cause variations in controller supply voltage making it necessary to take precautions against low voltage in order to prevent controller malfunction.



Should there be a risk that the +24 V at the PM8xx power terminals could drop below 19.2 V for more than 1 ms, then an energy reservoir must be used for Powering Units.

ABB strongly recommends using a DC/DC converter and extra energy reservoir in case external DC-supply with longer cables than 10 m is used.

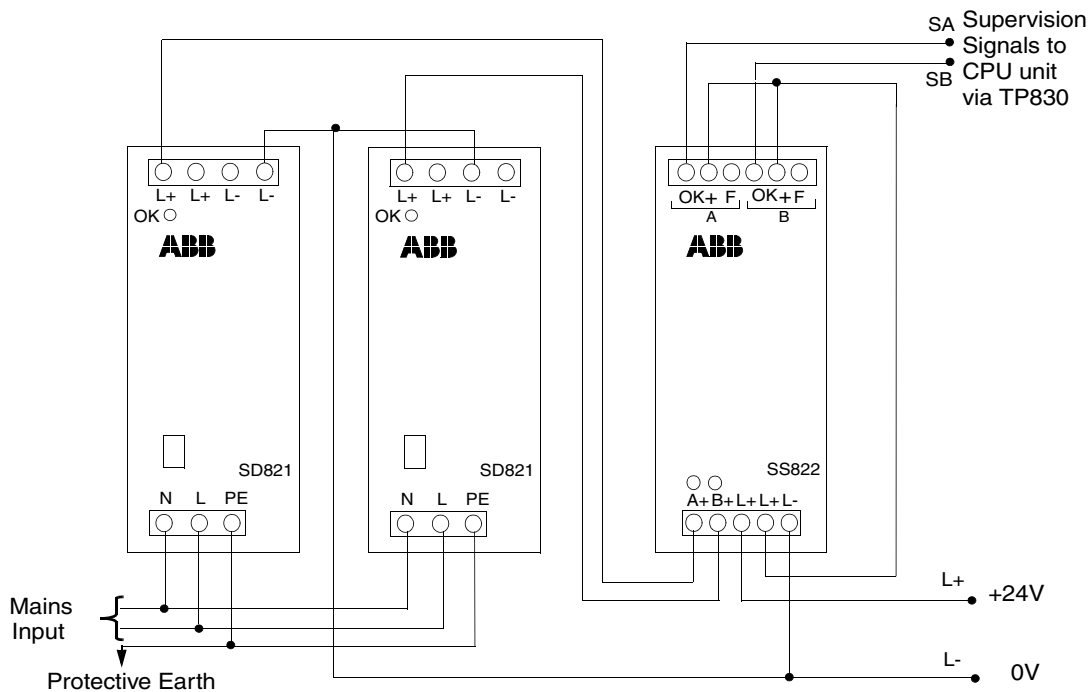

Figure 7. Example of a Redundant Power Supply Configuration

## I/O System

There are several methods of connecting I/O systems to the AC 800M Controller:

- S100 I/O via CI856.
- S800 I/O units via the ModuleBus. Support for hot configuration during run, redundancy on all levels, HART routing, and Sequence-of-Events (SOE).
- S800 I/O units via CI854/CI854A and CI840, PROFIBUS DP. Support for HART routing, redundancy on all levels, and hot configuration during run.
- S800 I/O units via CI854/CI854A and CI801, PROFIBUS DP. Support for HART routing, and hot configuration during run.
- S900 I/O units via CI854/CI854A, PROFIBUS DP.
- ABB Drives can be connected to the ModuleBus, via CI801. Some Drives equipment can be connected directly to PROFIBUS or PROFINET IO. Please refer to Drives-specific documentation for more information.
- Genius remote I/O (TRIO) via the CI862.
- Satt I/O on ControlNet (19" Satt rack I/O, S200 I/O and S200L I/O) via the CI865.
- PROFINET IO via CI871

For further information about supported I/O-units, refer to I/O-specific documentation, see [Released User Manuals and Release Notes](#) on page 16.

### S800 I/O

See [Figure 8](#) on page 40 for examples of AC 800M / S800 I/O interconnection.

The top right area of [Figure 8](#) on page 40 shows one cluster (or group) of units, connected to the built-in electrical ModuleBus of an AC 800M Controller. The maximum number of units per cluster is 12. However, a further seven clusters, each

comprising of up to 12 units, can be added to the optical ModuleBus. This results in a total count of 96 units for the local ModuleBus.



In redundant CPU configuration, connection of S800 I/O is done only with the optical ModuleBus. See [Figure 9](#) on page 41. Each cluster of I/O units is connected to two TB840s. Each processor unit is connected to one of the TB840s. Note that the built-in electrical ModuleBus can not be used in redundant CPU configuration.



Note that a PM851/PM851A is restricted to one optical ModuleBus cluster.

### S100 I/O

S100 I/O are connected to the AC 800M, via the communication unit CI856. A bus extension cable TK575/TK580, together with DSBC174/DSBC176 or DSBC173A, connects the S100 I/O units to the base plate, TP856, of CI856. Up to five S100 I/O racks can be connected to the CI856.

Redundant S100 I/O bus extension can not be connected to CI856.

### S900 I/O

S900 I/O are connected to the AC 800M, via PROFIBUS DP and CI854/CI854A. The S900 I/O system is a remote I/O system for use in hazardous areas. Due to its explosion protection certificates, the S900 process I/O system can be installed in both hazardous areas (zone 1 and zone 2) and safe areas.

### Other I/O Systems

A PROFIBUS DP segment (or node), shown on the top left-hand side of [Figure 8](#) on page 40, allows for a large increase in the numbers of units connected to each AC 800M Controller. The segment is shown here with a Fieldbus Communications Interface (FCI) unit (type CI840), connected to the PROFIBUS DP network. The use of FCI units, or other types of adapters, allows the selection of units from several I/O families.

### Genius remote I/O (TRIO)

TRIO is a remote I/O product that provides discrete, analog and high-speed counter blocks for connection to the AC 800M. Configuration of the I/O block units and the CI862 is done using Control Builder M.

The CI862 Communication Expansion Module (CEM), connects a TRIO Field Bus to the controller AC 800M. The connection between CI862 and AC 800M is done via the CEX-Bus.



CI862 cannot be used in an AC 800M High Integrity controller.

A single CI862 can connect 30 blocks to a single LAN. The AC 800M can have up to four single lans or four redundant lans. The maximum I/O with TRIO in an AC 800M is 1000 IO points.The CI862 can be set redundant.

TRIO blocks, are self-contained, configurable I/O blocks used to interface field devices to the CI862 communications bus. These blocks can be individually installed on machines, in junction boxes, or grouped in racks or panels. A TRIO block is made of cast aluminum, and weighs approximately 1.8 kg (4 pounds). It measures approximately 22.5 x 10 x 7.5 cm (9 x 4 x 3 inches). Each block has its own communications capability and microprocessor, and provides from 6 to 32 circuits for connecting input and output devices. You can place blocks on the bus in any combination or sequence. You can use a mix of blocks on the same bus.

### Satt I/O interface

The Satt I/O system consists of Rack I/O and Series 200 I/O family (S200 I/O, S200L I/O and I/O 200C). CI865 connects to Rack I/O, via the adapter 200-RACN, and to Series 200 I/O family, via the adapter 200-ACN.

The CI865 module is the AC 800M system's communication interface for Satt ControlNet and bridges different bus standards used on AC 800M and Satt ControlNet. The CI865 module makes it possible to use older Satt I/O system (Rack I/O and Series 200 I/O) with the AC 800M controller platform but it can not be used as a general ControlNet interface. CI865 supports online replacement (Hot Swap), and does not require any configuration before installation.



CI865 cannot be used in an AC 800M High Integrity controller.

**FOUNDATION Fieldbus High Speed Ethernet (FF HSE)**

The FF HSE communication interface unit CI860 makes it possible for AC 800M controllers to communicate with FF HSE devices via Ethernet. The FOUNDATION Fieldbus Linking Device LD 800HSE (see [Appendix B, Recommended Components](#)) makes it possible for AC 800M controllers to communicate with FOUNDATION Fieldbus H1 devices, via CI860 and Ethernet. An example system structure with a single CPU is given in [Figure 10](#) on page 42. An example system structure with a redundant CPU is given in [Figure 11](#) on page 43.



CI860 cannot be used in an AC 800M High Integrity controller.



The following schematic figures, with examples of I/O interconnections, do not necessarily show the exact amount of connectors or their exact positions.

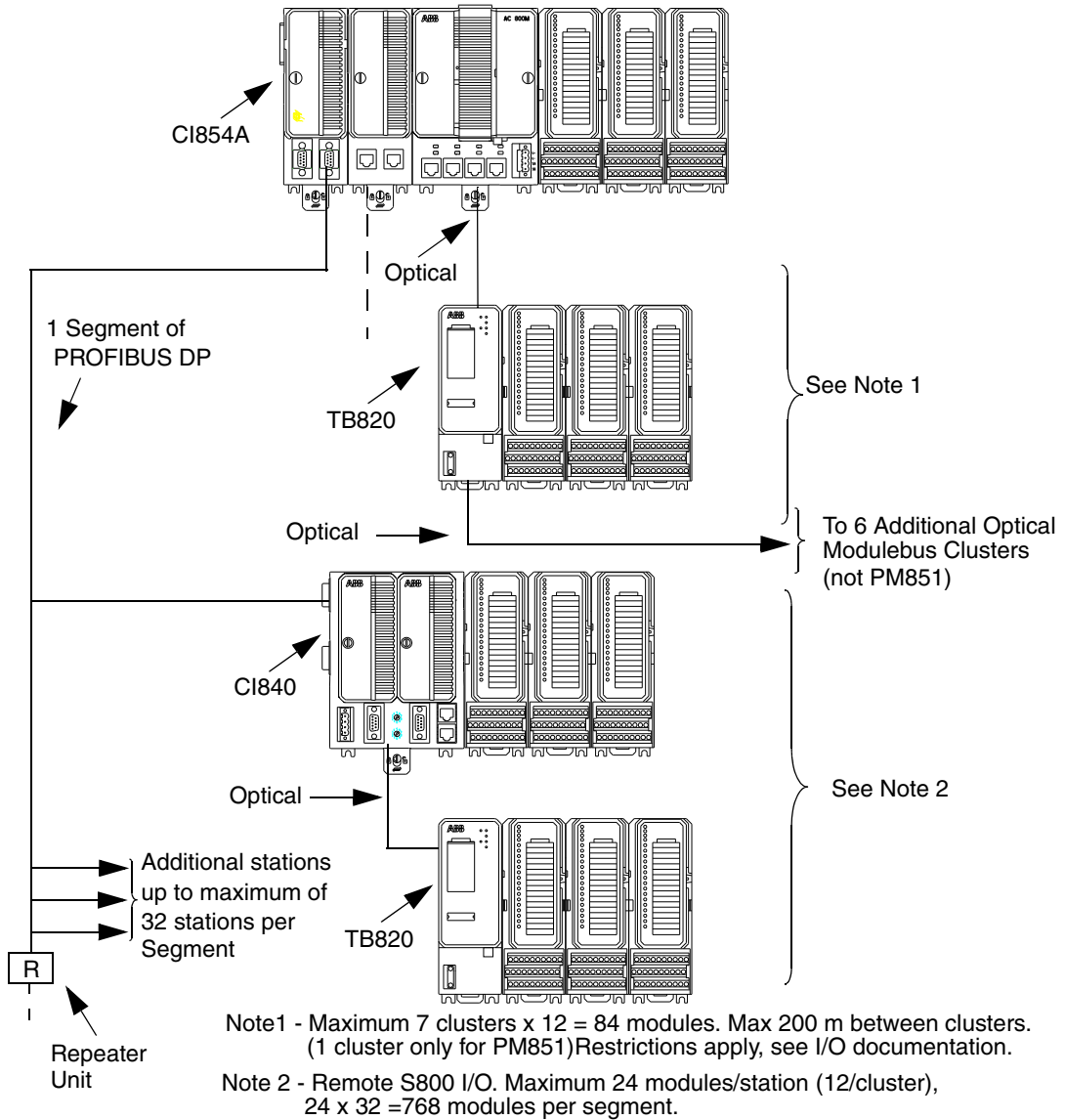

Figure 8. Example of AC 800M / S800 I/O Interconnection in Single CPU Configuration



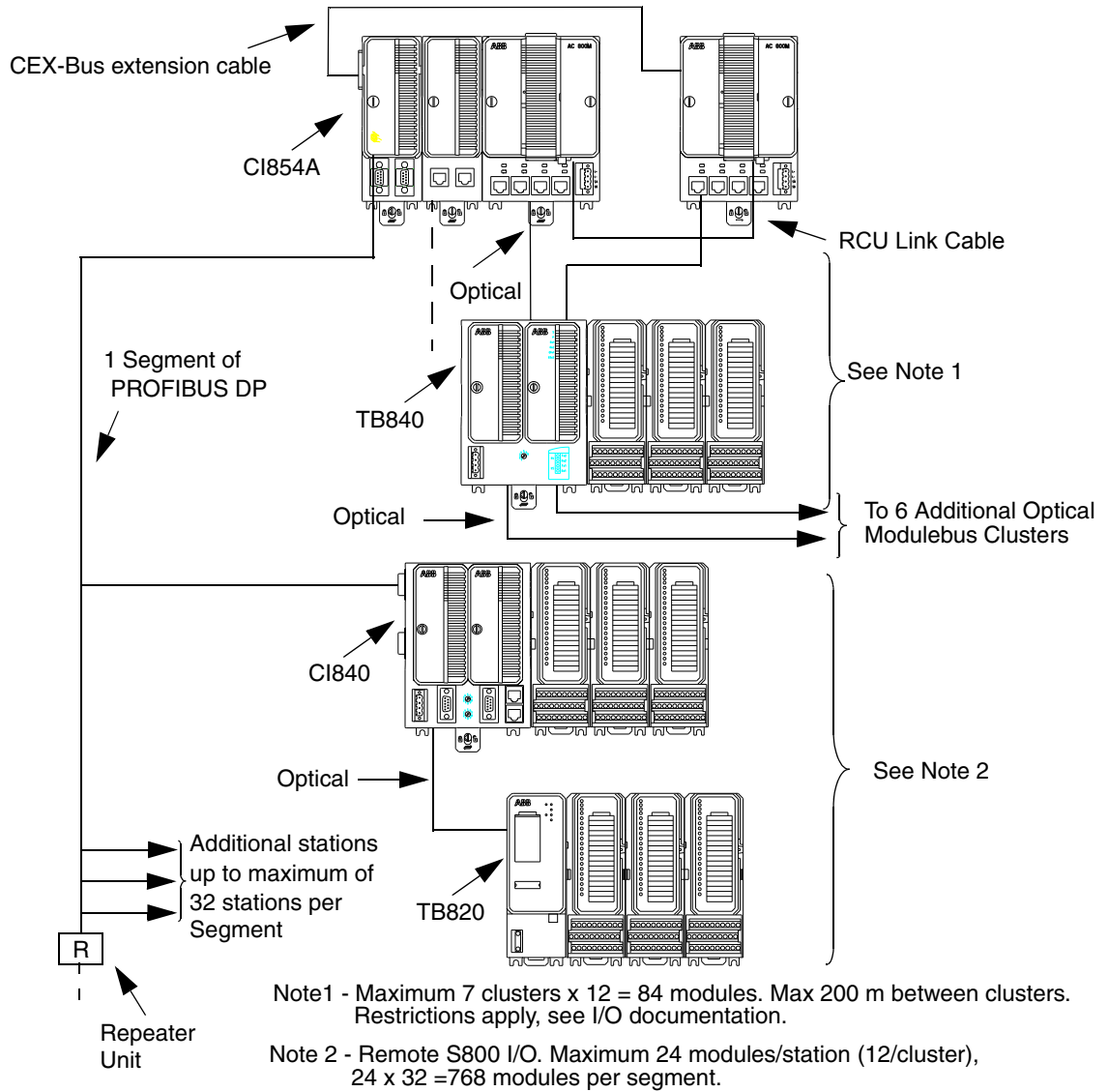

Figure 9. Example of AC 800M / S800 I/O Interconnection in Redundant CPU Configuration

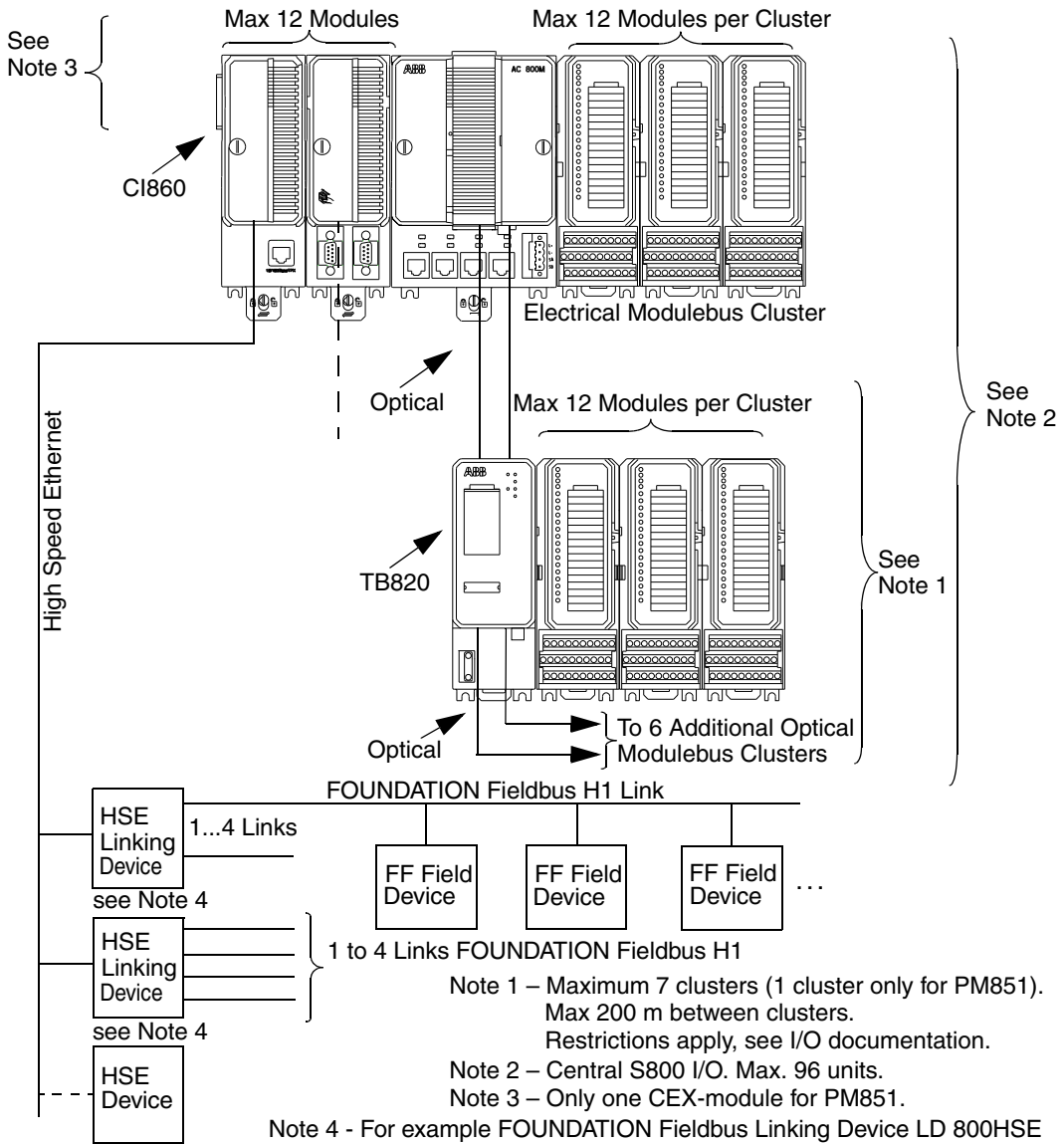

Figure 10. Example of AC 800M / S800 I/O and FOUNDATION Fieldbus High Speed Ethernet Interconnection in Single CPU Configuration

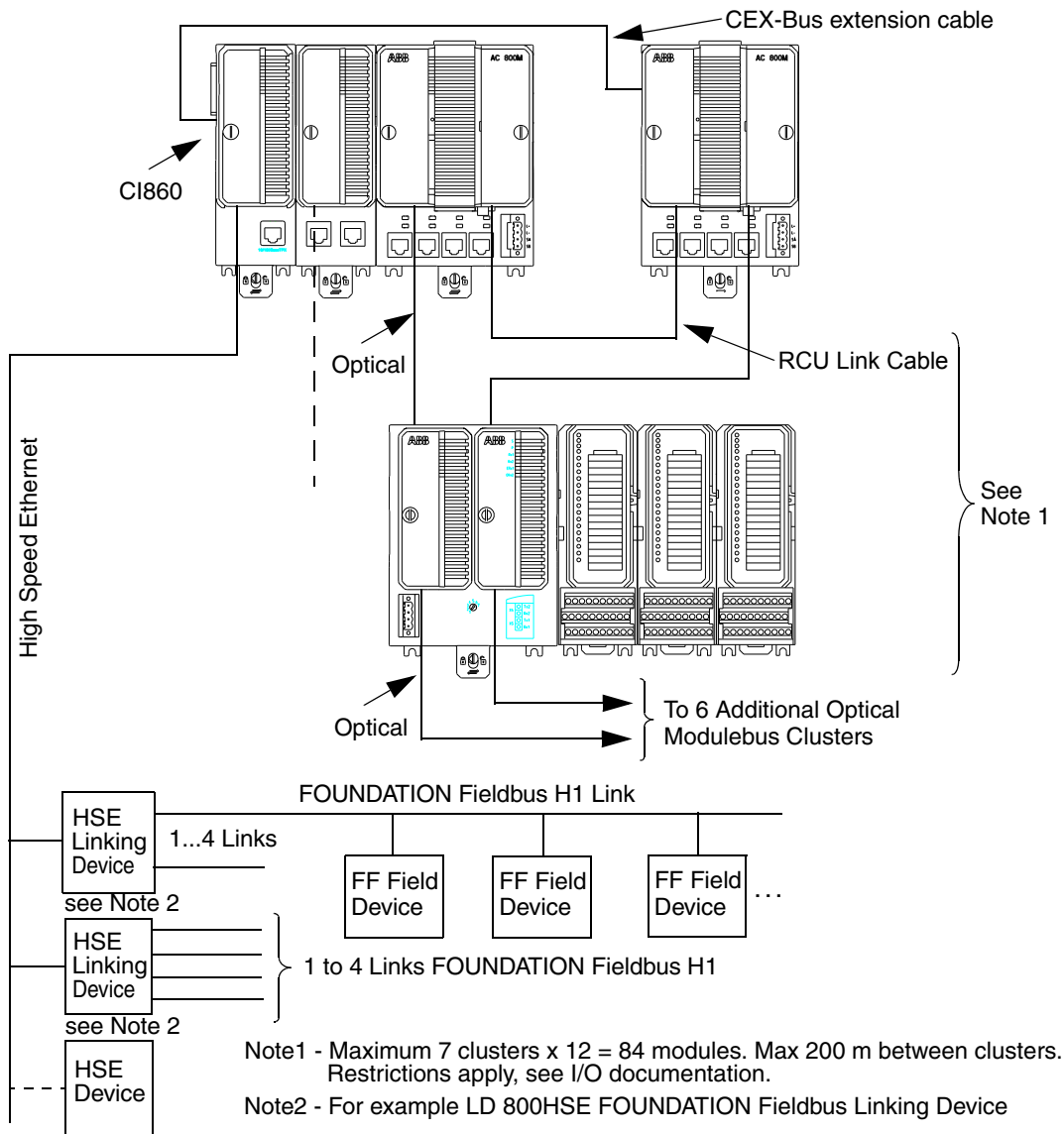

Figure 11. Example of AC 800M / S800 I/O and FOUNDATION Fieldbus High Speed Ethernet Interconnection in Redundant CPU Configuration

## Drive System

ABB Standard (Std) and Engineered (Eng) Drives can be connected to AC 800M through any of the following:

- The optical ModuleBus
- CI801 and PROFIBUS DP
- NPBA-12, RPBA-01, or FPBA-01 PROFIBUS DP Adaptor modules along with CI854
- RETA-02 or FENA-01/-11 Ethernet Adapter modules along with CI871 (PROFINET IO)
- CI858 DriveBus Interface.



CI858 cannot be used in an AC 800M High Integrity controller.

### ModuleBus

In single CPU configuration, ABB Drives can be connected to the processor unit via the optical ModuleBus. See [Figure 12](#) on page 47. The number of ABB Drives which can be connected to the optical ModuleBus, can be described by the following equation:

$$(\text{No. of ABB Drives}) \leq 84 - (12 \times (\text{No. of TB820s}))$$

that is, each Drive uses one ModuleBus cluster.

### PROFIBUS

In single and redundant CPU configuration, ABB Drives can be connected via PROFIBUS DP and CI801. See [Figure 12](#) on page 47. Only Standard Drives can be connected to CI801. Fourteen (14) Standard Drives can be connected to each CI801 if there are no I/O units connected. For the number of Drives that can be connected to the same CI801, when both I/O units (TB820) and Standard Drives are connected, refer to documentation about FCI for PROFIBUS DP.

For more information about ABB Drives and its types (Std and Eng) refer to S800 I/O documentation.

For information about Branching Unit (See [Figure 12](#) on page 47) see ABB Drive System documentation.

ABB drives can also be connected via PROFIBUS DP (CI854/CI854A), with direct connection to PROFIBUS DP slave modules NPBA-12, RPBA-01, and FPBA-01.

### **PROFINET IO and CI871**

The RETA-02 Ethernet Adapter module and FENA-01/-11 Ethernet Adapter module are optional devices for ABB drives, which enables the connection of the drive to a PROFINET IO (PNIO) network. The drive is considered as a PNIO device on the PROFINET IO network, and it is compatible with all PNIO controller stations that support PROFINET IO and sub-slots.

### **DriveBus Interface**

ABB drives can be connected to the AC 800M via the CI858 unit, see [Figure 12](#) on page 47 and [Figure 13](#) on page 48. The drive interface can be used for controlling up to 24 drives or inverter units.

Main communication functions of the drive connection are:

- dataset communication
- broadcast system time
- supervision and diagnostics functions

The data exchange between the AC 800M and the CI858 consists of eight datasets. The drive connection is able to transfer at the maximum 8 datasets / 1 ms.

Connection of multiple drives requires the use of a branching unit, which enables the construction of a logical bus with physical star topology, see [Figure 13](#) on page 48. The branching units can be chained.

The following drives are supported by the drive connection:

- ACS 600 single drive
- ACS 600 multi drive
- ACS 600 thyristor supply units
- ACS 600 IGBT supply units
- ACS 800 product family
- ACS 140-AC S400

- DCS 600 and DCS 400
- ACS 6000 product family / large drives
- ACS 1000 product family

For more information about ABB Drives and its types (Std and Eng) refer to S800 I/O documentation, see [Released User Manuals and Release Notes](#) on page 16.

For information about Branching Unit ([Figure 13](#) on page 48) see ABB Drive System documentation.



The following schematic figures, with examples of I/O interconnections, do not show the placement of the connectors.

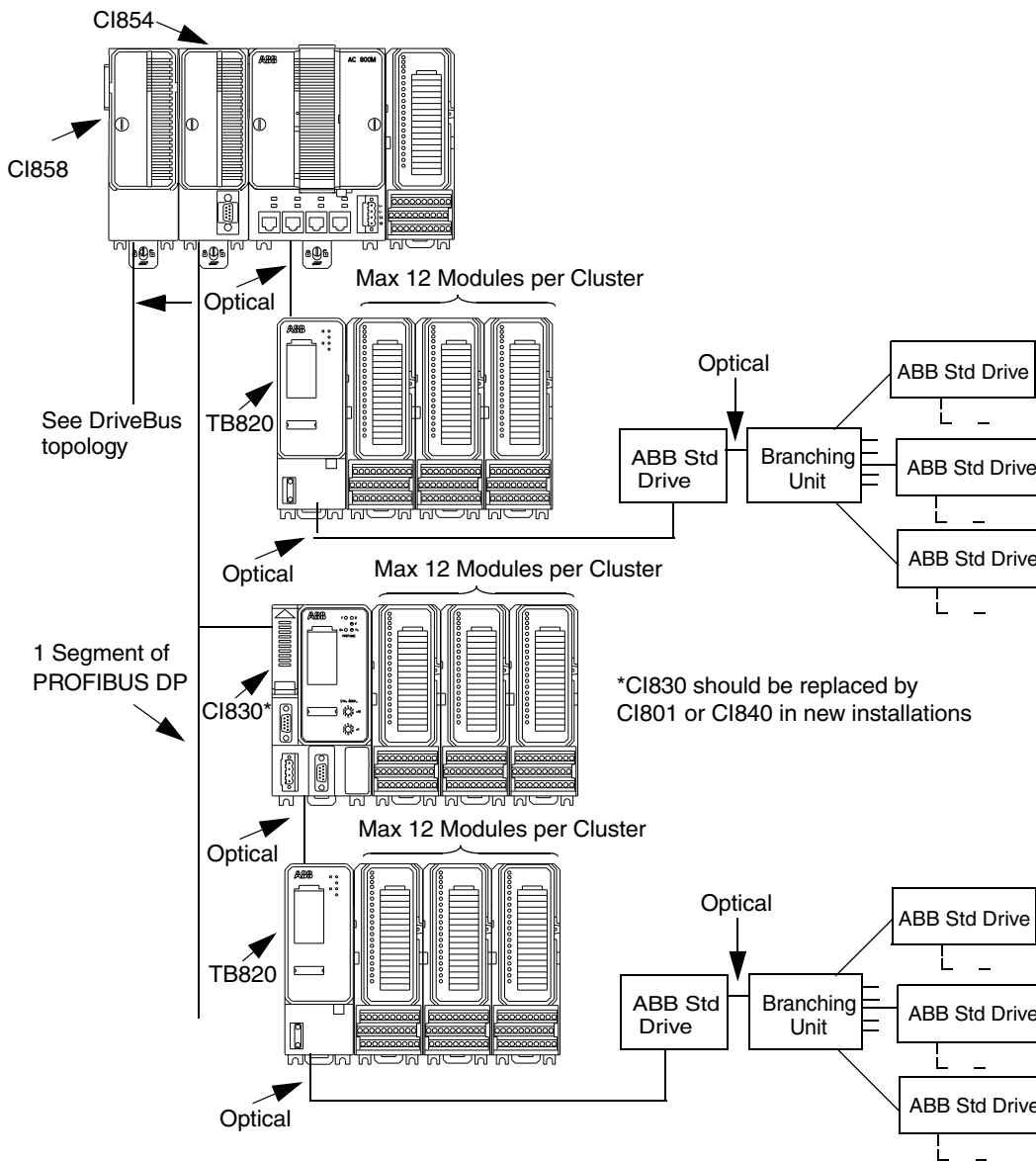

Figure 12. Example of Connection of ABB Drives in Single CPU Configuration

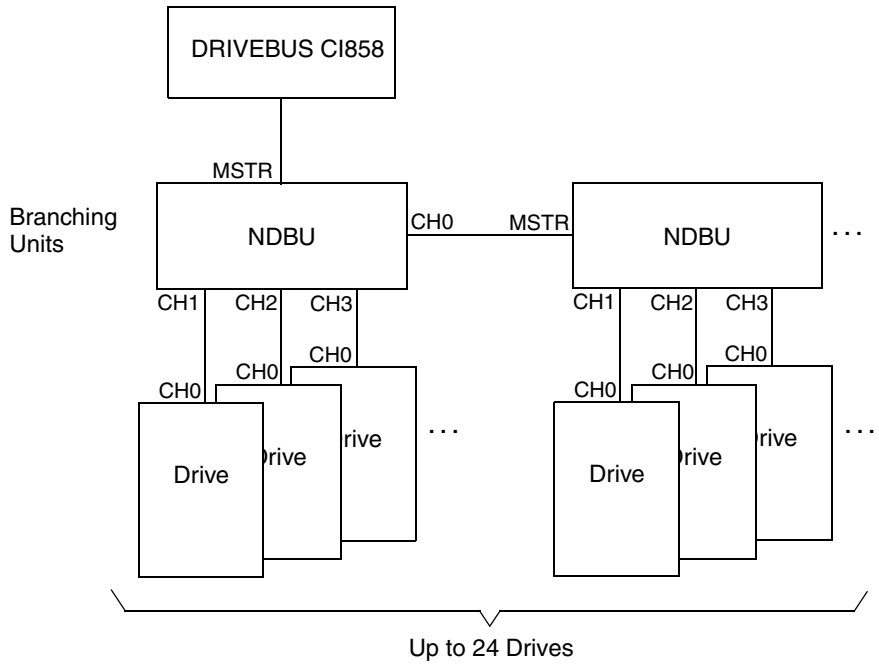

Figure 13. DriveBus Topology



## Installation

The AC 800M Controller consists of units that are mounted on a horizontal DIN rail as shown in [Figure 16](#) on page 51. Each base plate has a locking device that ensures contact between the metal back plate and the DIN rail, providing an effective ground connection. The locking device can be set to any of the following three positions, OPEN, SLIDE or LOCKED, which makes installation and removal of the base plates very simple.

There are two ways of mounting the products concerned in cabinets, open rack or other types of installations; aluminum profile with mounted DIN-rail, see [Figure 14](#), or DIN-rail mounted on a metal sheet of proper size, see [Figure 15](#).

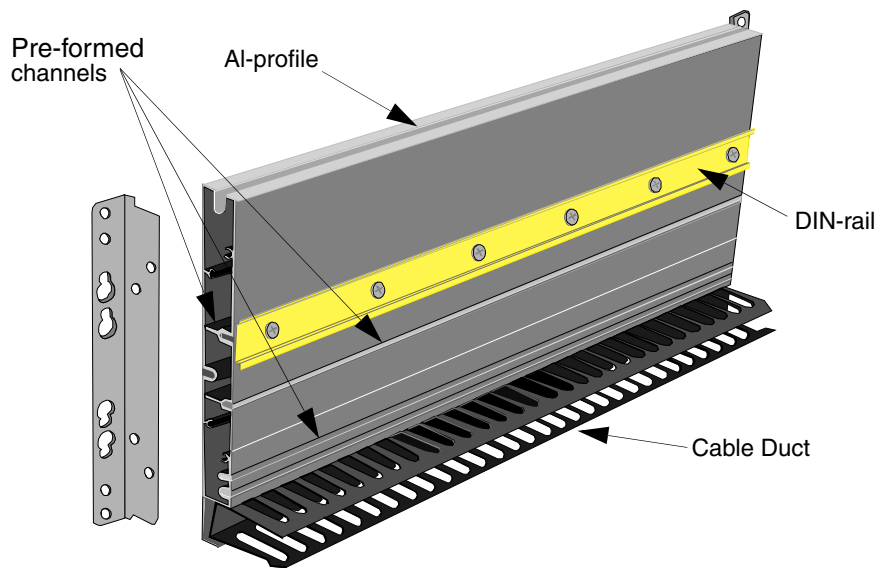

*Figure 14. Al-profile for DIN-rail support*

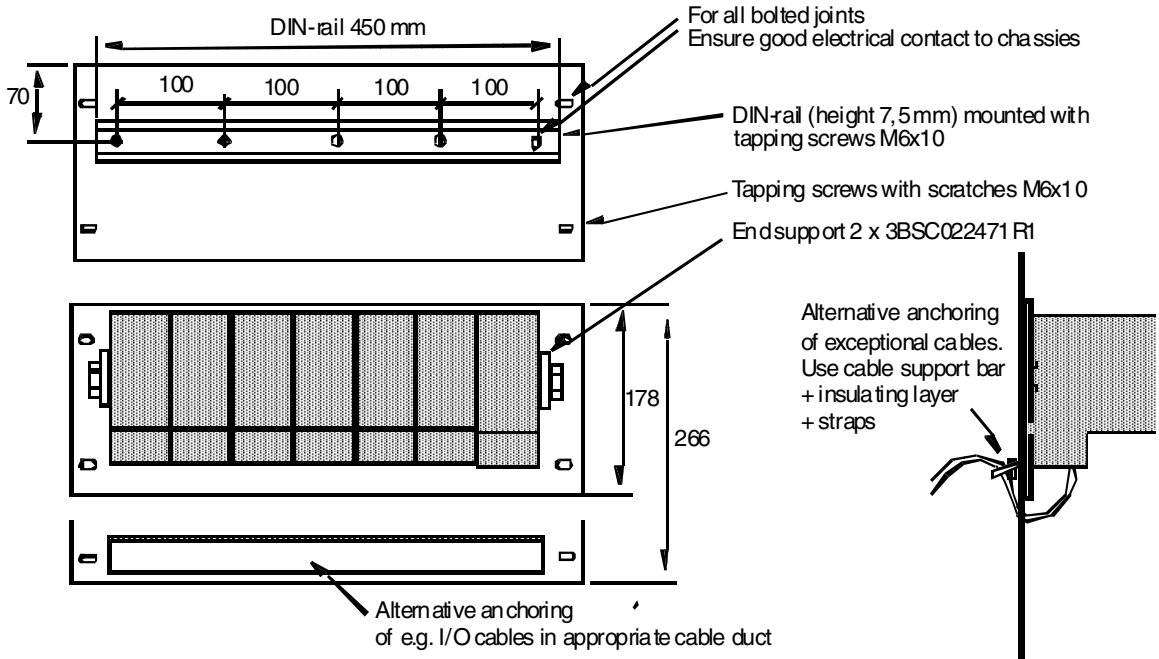

Figure 15. Mounted on Metal Sheet

The aluminum profile or metal sheet shall be properly connected to protective earth. DIN-rail type with height 7.5 mm shall be used. Refer to type NS 35/7.5 according to standard EN 50022.



It is not allowed to manipulate CEX bus base plates in a powered and running system. Before changing or removing a base plate, all CEX modules on that segment must be removed.

The AC 800M and S800 I/O-units have protection class IP 20. If a higher IP class is required, an additional enclosure is needed.

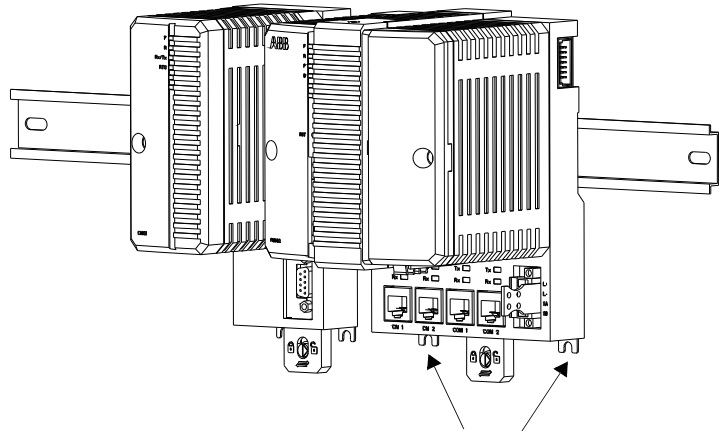

Lugs for extra screws to provide secure mounting in locations subject to vibration

*Figure 16. DIN Rail Mounting of AC 800M*

## Configuration

Using the Control Builder interface, it is possible to download controller firmware and configure hardware (I/O and communication units). It is also possible to make application programs with IEC61131-3 and compile and run programs off-line, as an aid to process simulation, before finally downloading an application to the controller.

The Control Builder interface is part of the Industrial IT 800xA System, which runs on a PC and is normally connected to the AC 800M controller via the Control Network, using the CN1 or CN2 port on the AC 800M controller. Alternatively, the PC could be connected to the controller via the controller COM4 port (RS-232C). In that case, use the tool cable TK212 and a serial port on the PC.



Note that a PM851/PM851A is restricted to one Ethernet (CN1) port, thus redundant Ethernet is not available.



Note that Control Builder as standard does not support CI862. If CI862 is to be used, suitable system extension must be installed.

---

## Section 3 Software Components

### General

The software used by the AC 800M Controller is named Control Software. This is a generic name for the scope of functions used in a controller, and does not stand for a specific software package.

These functions are:

- the hardware functions (supervision, communication buses, I/O buses, etc.)
- the firmware functions loaded into the controller (real time executive system, real time clock, redundant communication, etc.)
- the application program loaded into the controller (library functions, communication protocols, etc.)

To produce an application, it is necessary to use the Control Builder interface, which is part of Industrial IT 800xA System.

AC 800M is delivered without Control Software. To provide the controller with Control Software it is necessary to first load the firmware, and then download the application separately, using the Control Builder download function.

However, the processor unit is provided, at delivery, with firmware which enables the use of the CN1 or CN2 ports. The released firmware (from the delivery media) must always be downloaded to the CPU before any application program is downloaded. If there is no firmware pre-loaded into the CPU, the COM 4 port must be used.



Note that a PM851/PM851A is restricted to one Ethernet (CN1) port, thus redundant Ethernet is not available.



Always check that the CPU and other hardware units have the correct firmware version, before installing them. If the CPU is empty, CPU firmware must be loaded via the COM4 port.

For information about the application program, firmware, downloading and types of different licenses refer to [Released User Manuals and Release Notes](#) on page 16.

---

## Section 4 Hardware Components

### PM8xx Processor Unit - Single Configuration



This topic does not apply to PM891. See [PM891 Processor Unit - Single Configuration](#) on page 58.

The processor unit consists of two parts:

- Processor unit  
(PM851/PM851A/PM856/PM856A/PM860/PM860A/PM861/PM861A/  
PM864/PM864A/PM865/PM866), with CPU and Power Supply boards
- Base plate (TP830), housing the unit termination board

The CPU board contains the microprocessor and RAM memory, a real-time clock, LED indicators, INIT push button, and a CompactFlash interface.

The main function of the power supply board is to generate isolated, short circuit proof +5 V and +3.3 V supplies, for the CPU and I/O units. The board also contains opto-isolated RS-232C drivers / receivers for the service port, together with a back-up battery holder for memory / real time clock, (RTC).

The termination board, housed in the TP830 base plate, is where the majority of the external connections are attached. It is grounded to the DIN rail by means of the metallic components of the housing. The termination board is provided with: screw terminals for power supply (L+, L-); redundant power supply monitoring (supervision signals SA, SB); RJ45 connectors for the control network, serial port and service port; connectors for the electrical ModuleBus and the CEX-Bus. All units on the CEX-Bus and the electrical ModuleBus are powered by the 24 V d.c. connected to the base plate. The CN1 and CN2 ports are used for connection of

Control Network. CN1 should be used in a single network. Both ports should be used for a redundant network.



Note that a PM851/PM851A is restricted to one Ethernet (CN1) port, thus redundant Ethernet is not available.

The COM3 is an RS-232C port with modem signals. The following are protocol examples: MODBUS, COMLI, Siemens 3964R or custom designed protocols. The COM4 port is an alternate connection port to the Control Builder using the TK212 cable.



The processor unit has a communication expansion bus connector located on the left-hand side of the TP830 base plate. This CEX-Bus provides extension of the on-board communication ports with additional communication units.

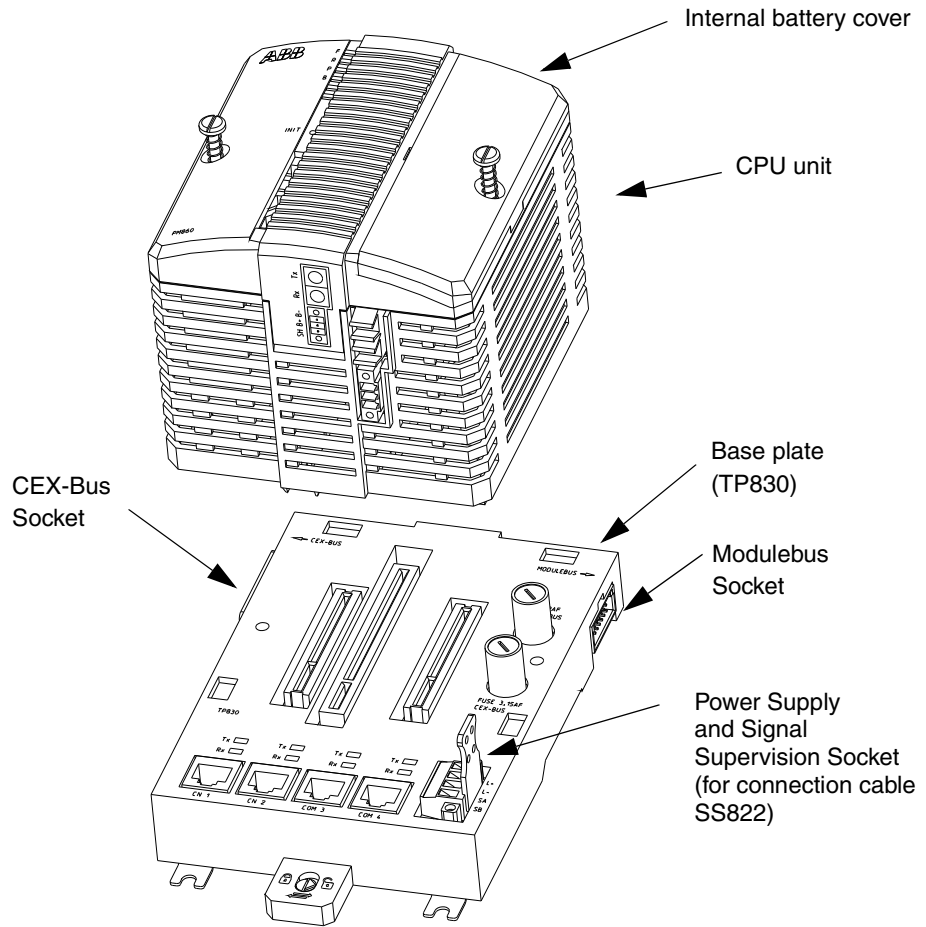

Figure 17. Processor Unit Assembly - General View (shown here with PM860 / TP830)

## PM891 Processor Unit - Single Configuration

The PM891 processor unit is a monolithic unit equipped with power supply and CPU-boards, and unit termination.

The unit contains the microprocessor and RAM memory, a real-time clock, LED indicators, INIT push button, and a Secure Digital interface.

The PM891 does not contain any internal battery.

The main function of the power supply board is to generate isolated, short circuit proof +5 V and +3.3 V supplies, for the CPU and I/O units. The board also contains opto-isolated RS-232C drivers / receivers for the service port.

The PM891 processor unit is grounded to the DIN rail by means of the metallic components of the housing. The unit consists of screw terminals for power supply (L+, L-); redundant power supply monitoring (supervision signals SA, SB); RJ45 connectors for the control network and service port; connectors for the optical ModuleBus and the CEX-Bus. All units on the CEX-Bus are powered by the 24 V d.c. connected to the unit. The CN1 and CN2 ports are used for connection of Control Network. CN1 should be used in a single network. Both ports should be used for a redundant network.

In single CPU configuration, it is possible to connect an S800 I/O cluster directly to the built-in optical ModuleBus plug located at the lower side of the unit.

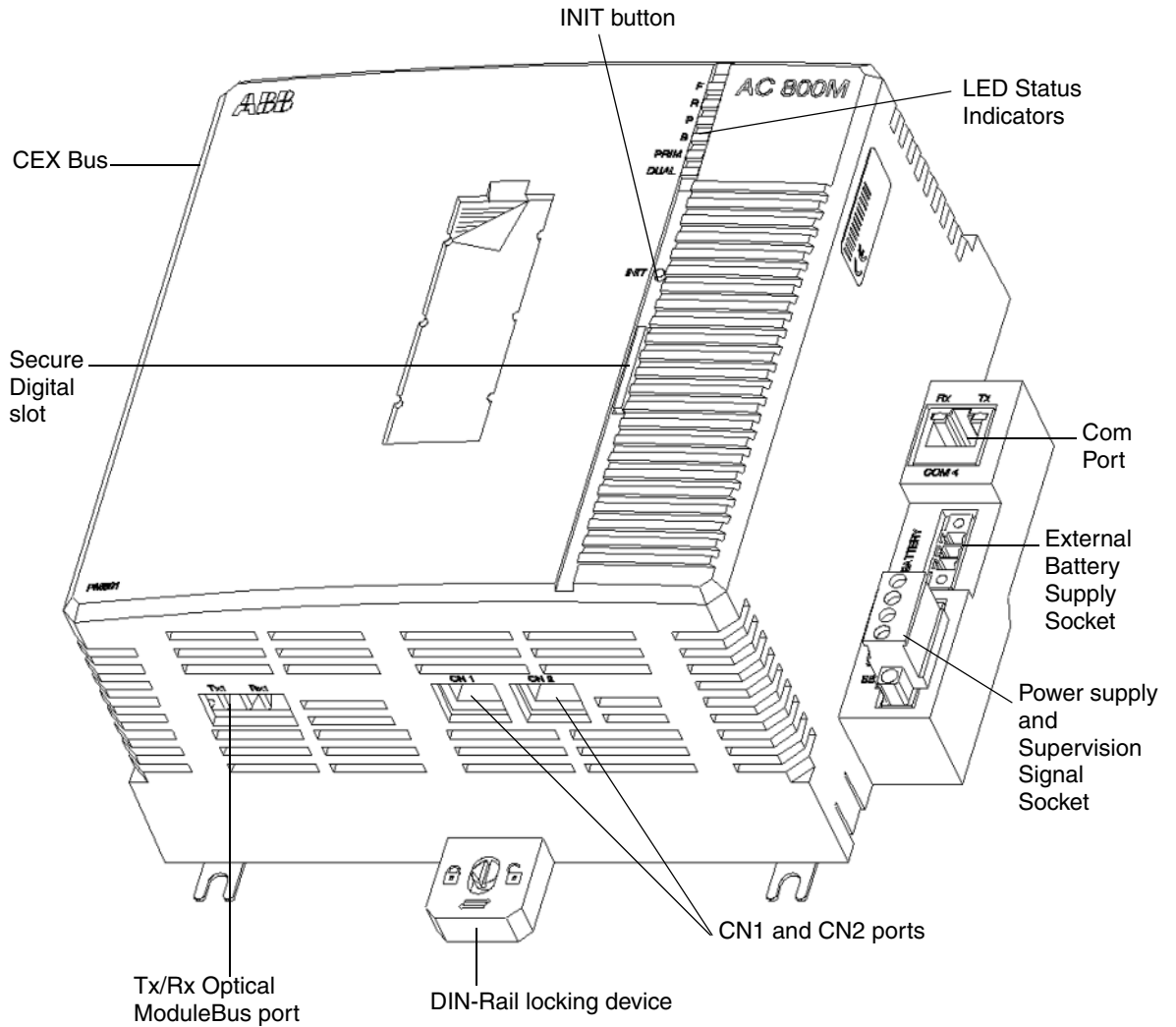

Figure 18. PM891 - Front view

## Processor Unit - Redundant Configuration

Processor unit redundancy is available. In this case, the controller contains two processor units, each including memory for system and application software. The primary processor unit controls the process. The backup stands by to take over in case of a fault in the primary. The changeover is done bumplessly and in less than 10 ms. During the changeover, the process outputs are frozen.

### PM8xx (Except PM891)

The PM861/PM864/PM865/PM866 has an RCU Link Connector for connection of the RCU Link Cable TK851, see [Figure 3](#) on page 25. In a redundant system, the two processor units are linked together with the RCU Link Cable. Both processor units are also connected to the same CEX-Bus, using either the TK850 CEX-Bus extension cable or through BC 810. Any one of the two can control the expansion units, see [Figure 19](#) on page 61.

S800 I/O units are connected to the two processor units with the optical ModuleBus and two TB840s. The built-in electrical ModuleBus on the base plates can not be used for connection of S800 I/O in redundant CPU configuration.

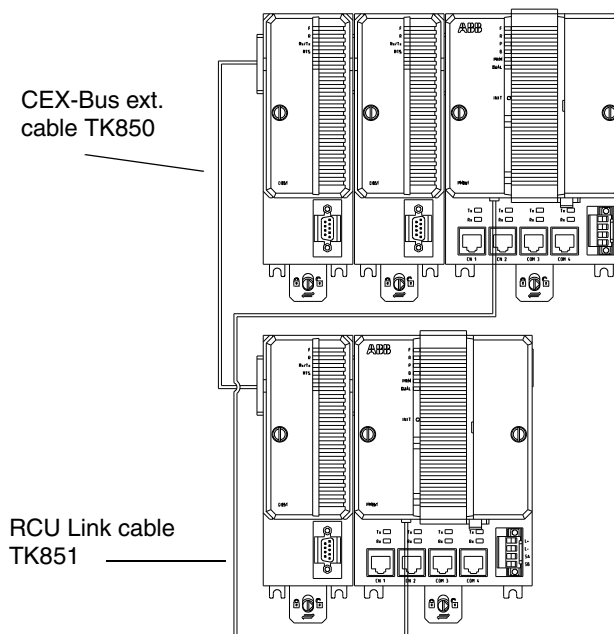

Figure 19. Connection of CPU Redundancy

## PM891

In PM891, the Redundancy Link consists of two cables – RCU Data Link Cable (TK855) and RCU Control Link Cable (TK856).

In a redundant system, the two processor units are linked together with both the RCU Link Cables. Both the processor units are also connected to the same CEX-Bus, using either the TK850 CEX-Bus extension cable or through BC 810. Any one of the two can control the expansion units.

S800 I/O units are connected to the two processor units with the optical ModuleBus and two TB840s.

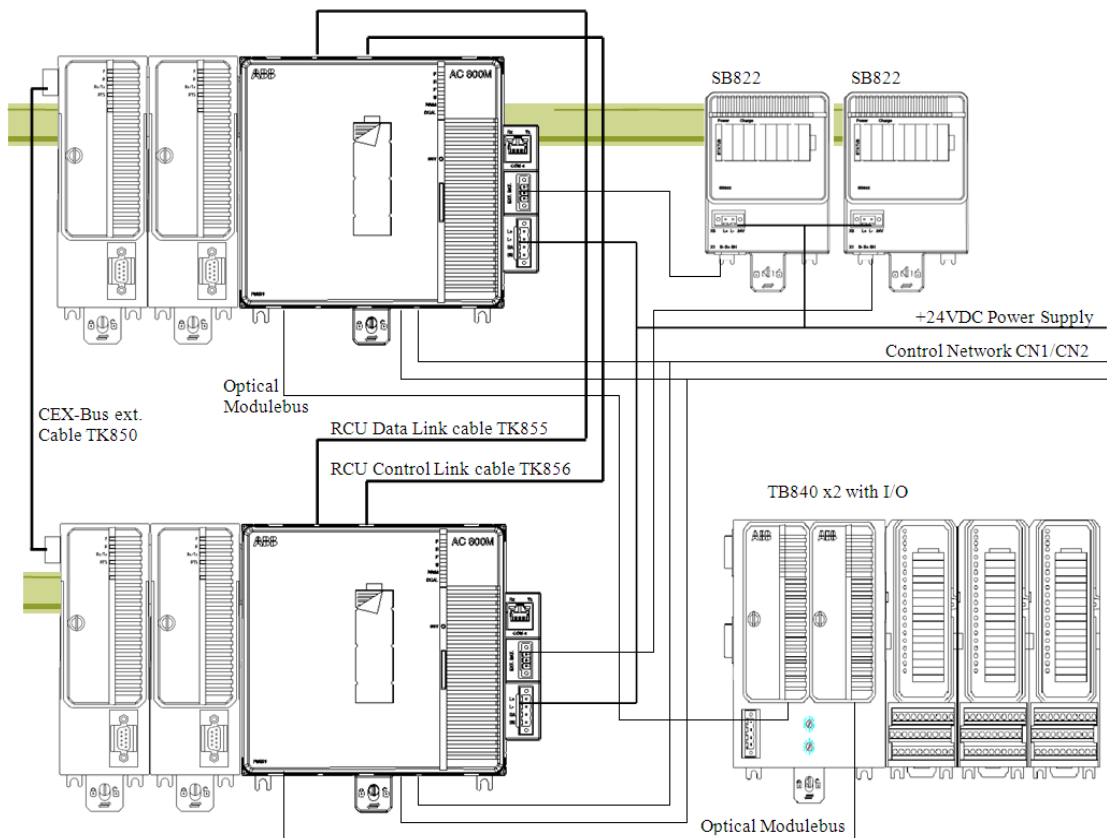

Figure 20. Example of Connection of CPU redundancy for PM891

## CEX-Bus Interconnection Unit - BC810 and TP857

The BC810 CEX-Bus Interconnection Unit, shown in [Figure 22](#) on page 65, offers a way to section the CEX-Bus into two independent segments. This improves availability in systems with redundant communication interfaces. [Figure 21](#) on page 64 shows a configuration example. The base plate has a preset, two letter Alpha code lock to prevent the installation of an incorrect type of unit onto the TP857 base plate.



It is not allowed to manipulate CEX bus base plates in a powered and running system. Before changing or removing a base plate, all CEX modules on that segment must be removed.

The BC810 is powered from the processor unit via the CEX-Bus and can also support the CEX-Bus with redundant power through its external connector for power supply.

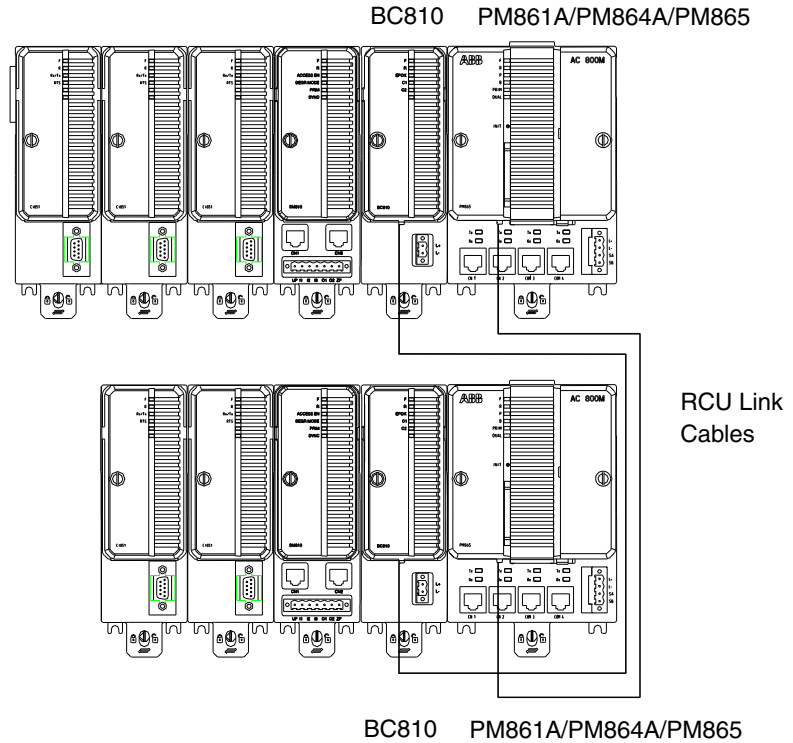
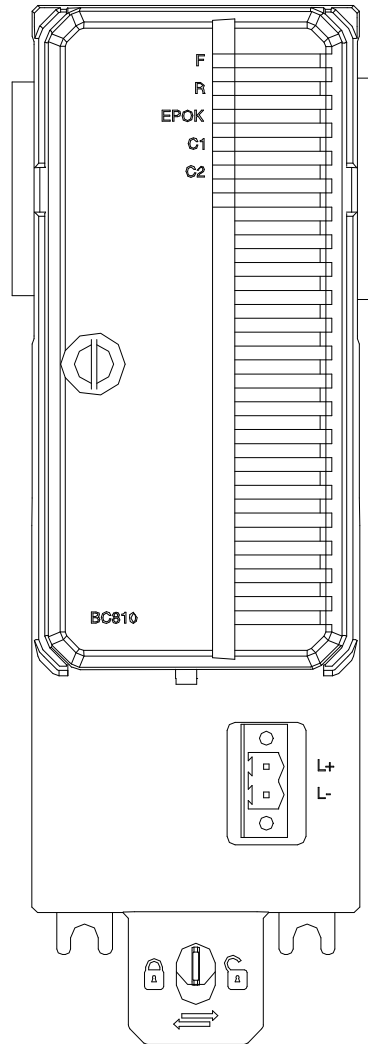

Figure 21. Redundant Communication Interface Units and Controllers





**Front View**  
**BC810 / TP857**

*Figure 22. CEX-Bus Interconnection Unit*

## SM810 and TP855

The prime function of SM810, shown in [Figure 23](#) on page 67, is to provide intelligent supervision of a controller during non-SIL and SIL1-2 operations.

For high availability applications it is possible to have redundant SM810's that work together with any of the two redundant CPUs.

The SM810 has a connector with three digital inputs and two digital outputs that can be used for safety related digital I/O (not process I/O). The input signals are used for system function, see Safety Manual, AC 800M High Integrity (3BNP004865R\*). For connection details see AC 800M Controller Hardware and Operation (3BSE036351R\*).

The base plate has a preset, two letter Alpha code lock to prevent the installation of an incorrect type of unit onto the TP855 base plate.

The SM810 is powered by the processor unit, via the CEX-Bus, and therefore does not require any additional external power source.

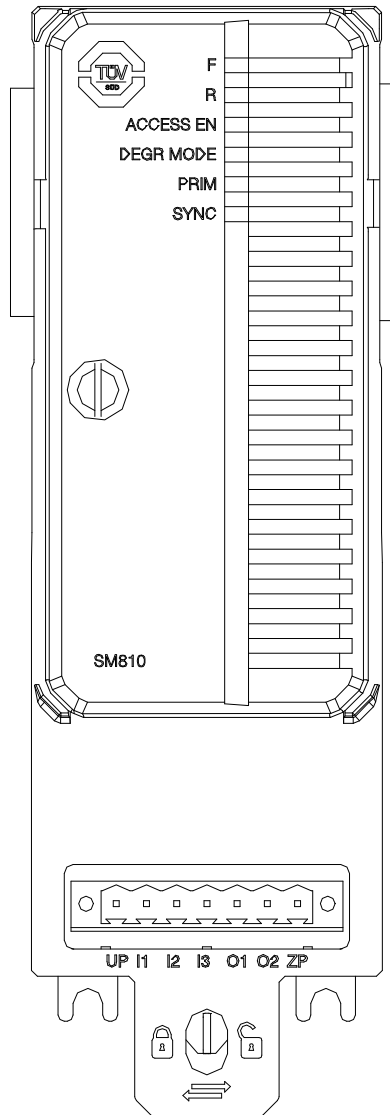

Figure 23. SM810

## SM811 and TP868

The prime function of SM811, shown in [Figure 24](#) on page 69, is to provide intelligent supervision of a controller during non-SIL and SIL1-2 operations, and together with a PM865 form a 1oo2 diverse structure for SIL3 applications.

For high availability applications it is possible to have redundant SM811's that work together with any of the two redundant CPUs. SM811 has a dedicated synchronization link to synchronize active and redundant SM for hot-insert and online upgrade. It is needed during hot-insert and on-line upgrade situations to copy data between two SM811s in a redundant setup.

The SM811 has a connector with three digital inputs and two digital outputs that can be used for safety related digital I/O (not process I/O). The input signals are used for system function, see Safety Manual, *AC 800M High Integrity (3BNP004865\*)*. For connection details see *AC 800M Controller Hardware (3BSE036351\*)*.

The base plate has a preset, two letter Alpha code lock to prevent the installation of an incorrect type of unit onto the TP868 base plate.

The SM811 is powered by the processor unit, via the CEX-Bus, and therefore does not require any additional external power source.

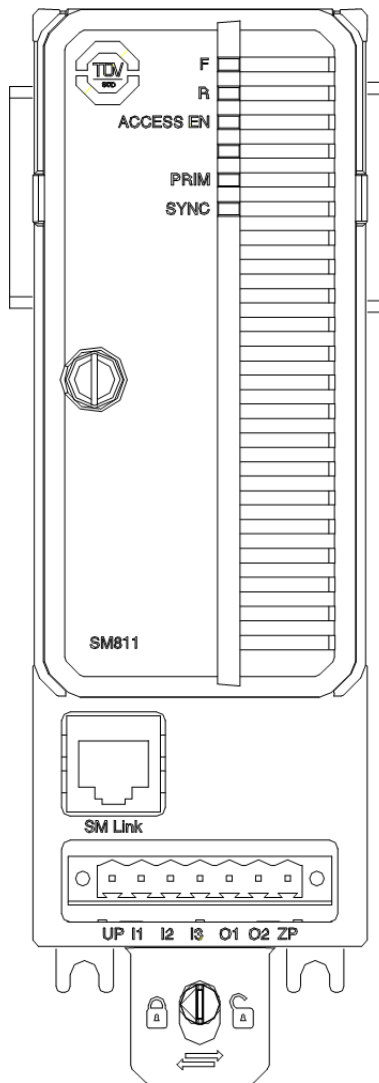

Figure 24. SM811

## Communication Interfaces

A communication interface unit comprises of two main assemblies:

- Communication Extension base plate which provides the CEX-Bus logic together with the necessary DIN rail mounting facilities.
- Communication Extension unit which contains an appropriate communication unit together with a d.c./d.c. converter to supply the appropriate voltages from the +24 V d.c., supplied from the CEX-Bus.



It is not allowed to manipulate CEX bus base plates in a powered and running system. Before changing or removing a base plate, all CEX modules on that segment must be removed.

By adding communication interfaces to the CEX-Bus, the number of protocols and processor unit ports can be expanded. The available CEX-Bus interface quantities are shown in [Table 2](#) on page 71.

Table 2. Interfaces Available on the CEX-Bus

Interface	Number of Interfaces on CEX-Bus		Number of ports per Interface
	Maximum of each interface	Maximum total on CEX-Bus <sup>(1)(2)</sup>	
CI851 (PROFIBUS DP)	12	12	1
CI852 (FOUNDATION Fieldbus H1)	12		1
CI853 (RS-232C)	12		2
CI854/CI854A (PROFIBUS DP)	12		2
CI855 (Ethernet for MasterBus 300)	12		2
CI856 (S100)	12		1
CI857 (INSUM)	6		1
CI858 (DriveBus)	2		3
CI860 (FOUNDATION Fieldbus HSE)	12		1
CI862 (TRIO)	4		1
CI865 (Satt I/O)	4		1
CI867 (MODBUS TCP)	12		2
CI868 (IEC 61850)	4		2 <sup>(3)</sup>
CI869 (AF100)	12		2
CI871 (PROFINET IO)	12		2 <sup>(3)</sup>
CI873 (EtherNet/IP)	4		2 <sup>(3)</sup>

(1) PM851/PM851A is restricted to a maximum of one CEX module.

(2) The maximum total limit on CEX-Bus is the electrical one, there might be further limitations due to performance for a particular unit.

(3) Only one port (CH1) is used in the interfaces CI868, CI871, and CI873

## PROFIBUS DP Interface - CI851 and TP851

The CI851 and TP851 assemblies, shown in [Figure 25](#) on page 73, are used for connecting remote I/O and fieldbus instruments via PROFIBUS DP. The TP851 base plate has one female DB9 connector for connecting PROFIBUS DP. The base plate has a preset, two letter Alpha code lock to prevent the installation of an incorrect type of unit onto the TP851 base plate.

The CI851 is powered by the processor unit, via the CEX-Bus, and therefore does not require any additional external power source.

The PROFIBUS DP must be terminated at the two outermost nodes. ABB recommend the use of connectors with built-in termination, since the fieldbus will then always be terminated, even if it is disconnected from the unit.

It is also possible to connect PROFIBUS PA to the CI851 via the PROFIBUS linking device LD 800P, see [Appendix B, Recommended Components](#).



It is not possible to change the CI851 via Hot swap and it is not allowed to perform an online upgrade of firmware in a system containing CI851.



CI851 cannot be used in a High Integrity controller.



CI851 has been replaced by the CI854 communication interface. CI851 is only described for legacy reasons.



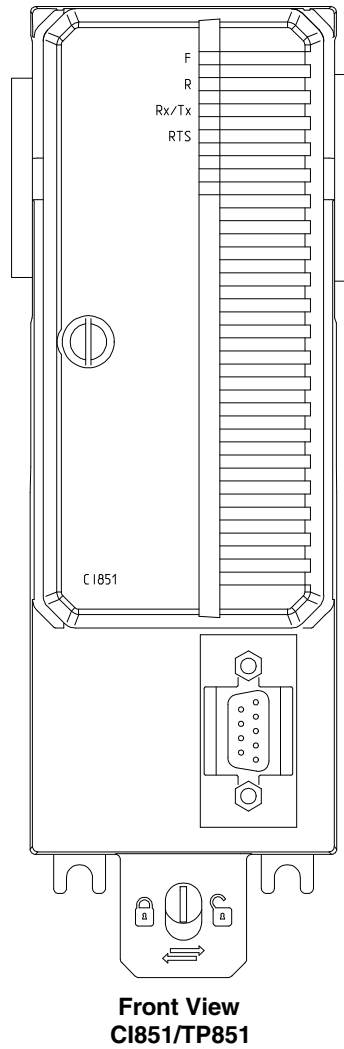

Figure 25. PROFIBUS DP Communication Interface

## RS-232C Interface - CI853 and TP853

The CI853/TP853 assemblies, shown in [Figure 26](#) on page 75, should be used when an extension of the processor unit, onboard RS-232C ports, is required.

An RS-232C channel, with full modem support, can be connected to each of the COM1 and COM2 ports. The two ports on a CI853/TP853, can be configured for different protocols.

The CI853 is powered by the processor unit, via the CEX-Bus, and therefore does not require any additional external power source.

If the cable lengths are required to be extended beyond 15 meters, a short distance modem, TC562, must be used. The TC562 is connected to the TP853 base plate or the TP830 base plate, using TK853 cable.

TC562 short distance modem allows cable lengths to be extended (depending on the modem transmission speed selected) to a distance of 18000 m (19700 yds) at 600 bit/s.

*Table 3. TC562 Short Distance Modem - Technical Data*

Item	Value
Type	TC562 - Short Distance Modem Manufacturer - Westermo - MD-12DC
Transfer	Asynchronous, full/half duplex/simplex, maximum 19200 baud
Power Supply	24V d.c. (Min. 12V d.c.- Max 36V d.c.)
Power Consumption	3W

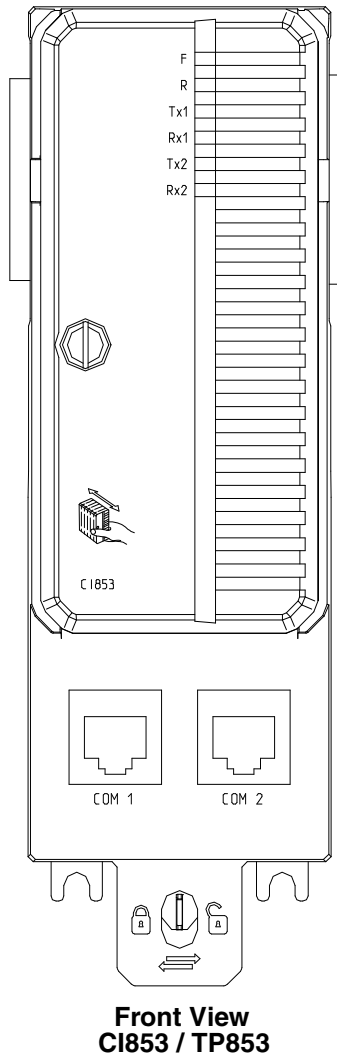

Figure 26. RS-232C Communication Interface

## PROFIBUS DP Interface - CI854/CI854A and TP854

The CI854/CI854A and TP854 assemblies, shown in [Figure 27](#) on page 77, are used for connecting remote I/O and fieldbus instruments via PROFIBUS DP. The TP854 base plate has two female DB9 connectors for connecting PROFIBUS DP with support of Line Redundancy. The base plate has a preset, two letter Alpha code lock, to prevent the installation of an incorrect type of unit onto the TP854 base plate.

The CI854/CI854A is powered by the processor unit, via the CEX-bus, and therefore does not require any additional external power source.

The PROFIBUS DP must be terminated at the two outermost nodes. This is usually done by using connectors with built-in termination. To guarantee a correct working termination the connector has to be plugged and power supplied.

It is also possible to connect PROFIBUS PA to the CI854A via the PROFIBUS linking device LD 800P, see [Appendix B, Recommended Components](#).

The CI854A can be set redundant.



Hot swap of CI854A is supported but not CI854.

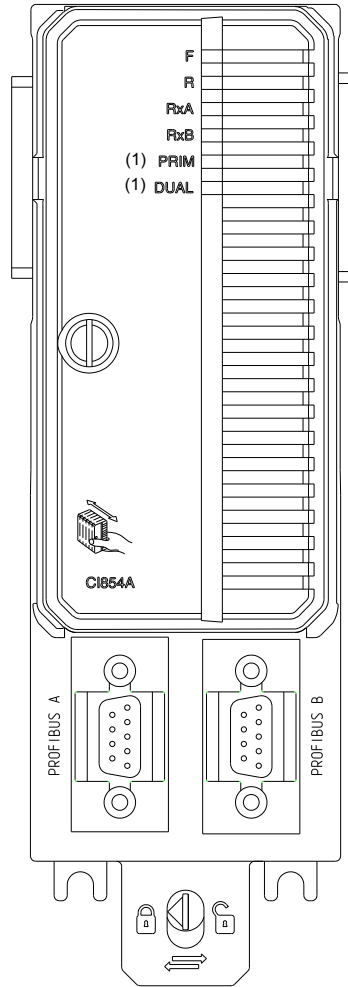

(1) CI854A only

**Front View**  
**CI854/ CI854A / TP854**

*Figure 27. PROFIBUS DP Communication Interface*

## MasterBus 300 Interface - CI855 and TP853

The CI855 and TP853 assemblies, shown in [Figure 28](#) on page 79, are used for connection of an AC 800M to single or redundant MasterBus 300 Networks. This allows DataSet communication and transmission of time between Advant Controller 410/450 and AC 800M.

The TP853 base plate has two RJ45 connectors for connecting MasterBus 300. The base plate has a preset, two letter Alpha code lock, to prevent the installation of an incorrect type of unit onto the TP853 base plate.

The CI855 is powered by the processor unit, via the CEX-Bus, and therefore does not require any additional external power source.

The connection to ethernet is made according to the general rules for connecting an ethernet node.



If interface to an AUI is required, a converter from 10 Base T to AUI is needed. The communication unit, CI855, can not provide power to the transceiver, therefore a separate power source for the transceiver must be provided.

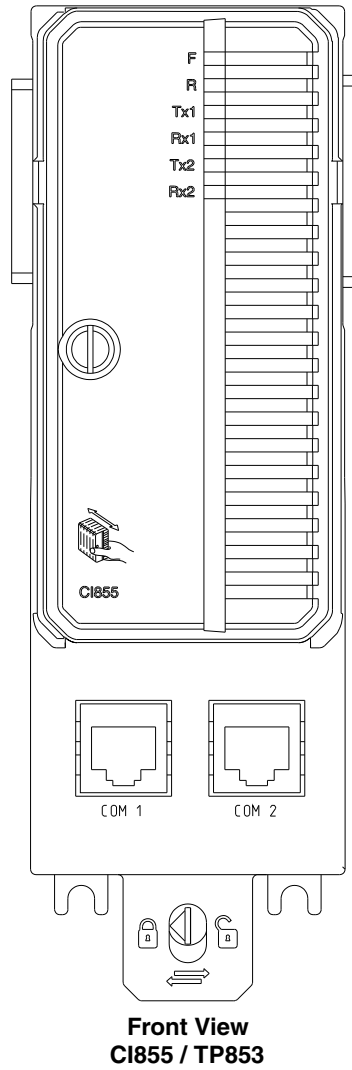

Figure 28. MasterBus 300 Communication Interface

## S100 I/O Interface - CI856 and TP856

The CI856 and TP856 assemblies, shown in [Figure 29](#) on page 81, are used for connecting S100 I/O to AC 800M. The TP856 base plate has one female 36 pin center line miniature ribbon connector, for connecting the TK575/TK580 bus extension cable from S100 I/O. A bus extender, DSBC174/DSBC176 or DSBC173A, must also be used. The base plate has a preset, two letter Alpha code lock to prevent the installation of an incorrect type of unit onto the TP856 base plate.

The CI856 is powered by the processor unit, via the CEX-Bus, and therefore does not require any additional external power source.

Supported S100 I/O are listed in System Guide Technical Data and Configuration Information (3BSE041434\*).



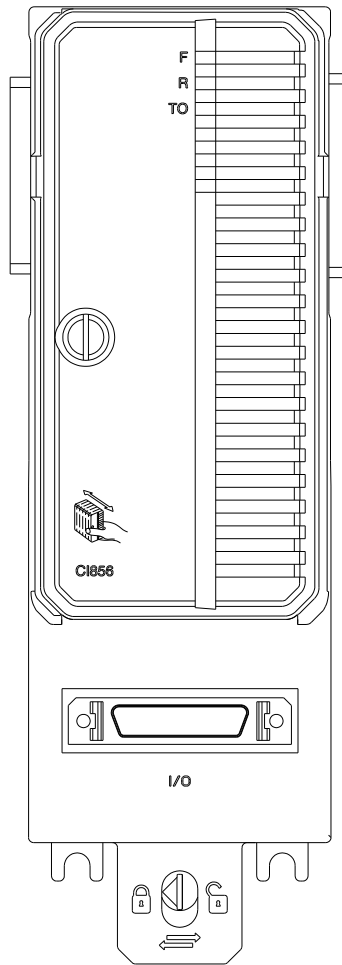

**Front View**  
**CI856 / TP856**

*Figure 29. S100 I/O Communication Interface*

## INSUM Interface - CI857 and TP853

The CI857 and TP853 assemblies, shown in [Figure 30](#) on page 83, are used for connection of an AC 800M controller with INSUM through TCP/IP over Ethernet and an INSUM TCP/IP Gateway which has a LON interface communicating with the underlying INSUM system.

The TP853 base plate has one RJ45 Ethernet connector (only COM1 is used for INSUM). The base plate has a preset, two letter Alpha code lock, to prevent the installation of an incorrect type of unit onto the TP853 base plate.

The CI857 is powered by the processor unit, via the CEX-Bus, and therefore does not require any additional external power source.

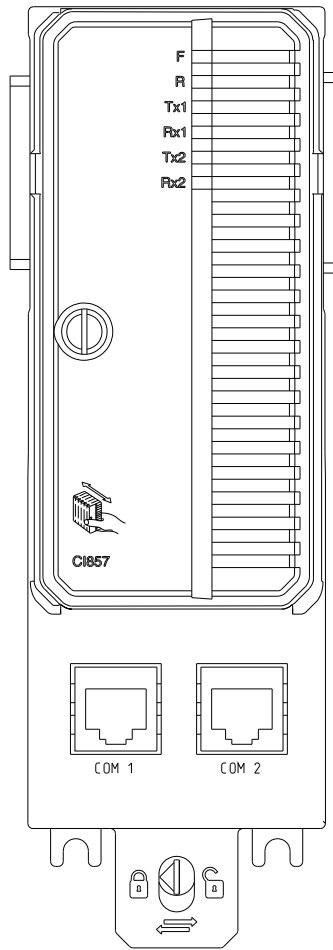

**Front View  
CI857 / TP853**

*Figure 30. INSUM Communication Interface*

## DriveBus Interface - CI858 and TP858

The CI858, shown in [Figure 31](#) on page 85, has three optical connectors. DriveBus connector for connection of ABB Drives, I/O connection, and a Tool connection for downloading firmware to the communication unit with the ABB Drives tools DriveDebug or DriveWindow.

The base plate has a preset, two letter Alpha code lock, to prevent the installation of an incorrect type of unit onto the TP858 base plate.

The CI858 is powered by the processor unit, via the CEX-Bus, and therefore does not require any additional external power source.



Firmware cannot be downloaded to the CI858 communication interface unit via Ethernet. Download of firmware to CI858 requires a Drives-specific download package. For information on how to download firmware to CI858, see ABB Drives documentation.



CI858 cannot be used in a High Integrity controller.

A maximum of two CI858 modules is supported per AC 800M controller.

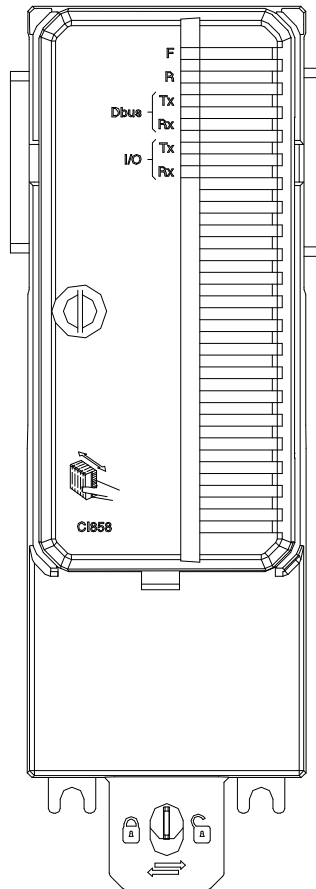

**Front View  
CI858/TP858**

*Figure 31. DriveBus Communication Interface*

## FOUNDATION Fieldbus High Speed Ethernet Interface - CI860 and TP860

The CI860 / TP860 assemblies, as shown in [Figure 32](#) on page 87, are used for connecting FOUNDATION Fieldbus High Speed Ethernet (FF HSE) devices to the AC 800M. It is also possible to communicate with FOUNDATION Fieldbus H1 devices, via the HSE Linking Device (LD 800HSE), see [Appendix B, Recommended Components](#). FF HSE has a communication speed of 10/100 Mbit/s.

The CI860 unit supports the FOUNDATION Fieldbus High Speed Ethernet interface. The FF HSE network is connected with an 8 pin RJ45 connector (COM) via the Base plate (Ethernet TP Standard). The base plate has a preset, two letter Alpha code lock, to prevent the installation of an incorrect type of unit onto the TP860 base plate.

The CI860 is powered by the processor unit, via the CEX-Bus, and therefore does not require any additional external power source.

The CI860 is connected, via a transformer, to the FF HSE bus and thus neither supplies nor consumes electrical power from the FF HSE bus. The FF HSE bus is a standard Ethernet cabling.

Connection of the Fieldbus Builder FF can be made via an OPC server FOUNDATION Fieldbus to the FF HSE network.



The CI860 can be set redundant and supports hot swap. CI860 cannot be used in a High Integrity controller.

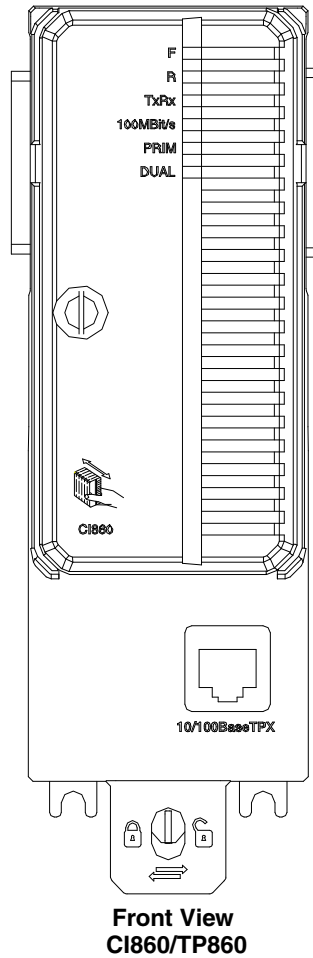

Figure 32. FOUNDATION Fieldbus High Speed Ethernet Communication Interface

## TRIO/Genius Remote I/O - CI862

TRIO is a Genius remote I/O product that provides discrete, analog and high-speed counter blocks for connection to the AC 800M. Configuration of the I/O block units and the CI862 is done using Control Builder M.

The CI862 Communication Expansion Module (CEM) [Figure 33](#), connects a TRIO Field Bus to the controller AC 800M. The connection between CI862 and AC 800M is done via the CEX-Bus.

A single CI862 can connect 30 blocks to a single LAN. The AC 800M can have up to four single lans or four redundant lans. The maximum I/O with TRIO in an AC 800M is 1000 IO points.

The CI862 can be set redundant.



The CI862 supports hot swap. CI862 cannot be used in a High Integrity controller.



The CI862 can be used in a redundant processor module configuration under the following conditions:

- a. If the CI862 is used with redundant PM866, only the TK850 CEX-bus extension cable shall be used for interconnection between the PM866 modules. The BC810 shall not be used.
- b. If the CI862 is used with other redundant processor modules (PM861A/PM864A/PM865), either BC810 or TK850 CEX-bus extension cable can be used for interconnection between the two processor modules.



The CI862 is not supported with the PM891 processor module.



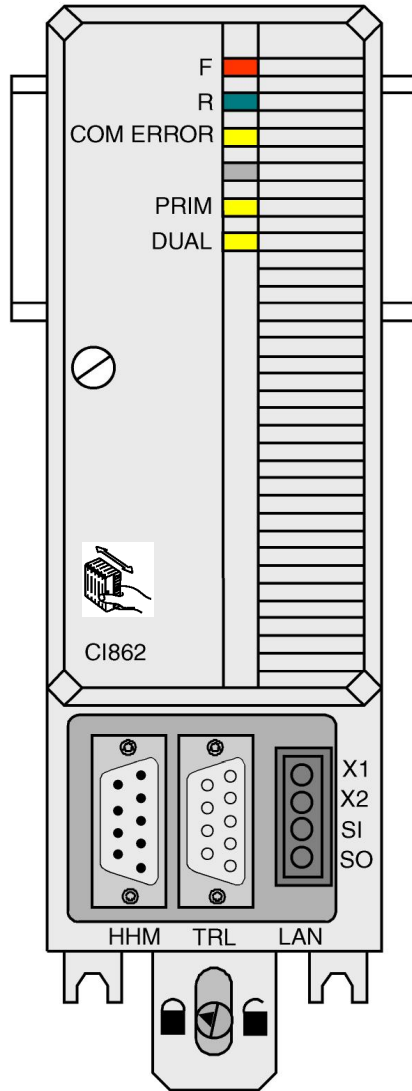

Figure 33. TRIO/Genius Fieldbus Communication Interface

## Satt I/O - CI865

The CI865 unit is the AC 800M communication interface for Satt I/O ControlNet. The CI865 unit makes it possible to use older Satt I/O system (Rack I/O and series 200 I/O) with the AC 800M controller platform. The unit handles I/O scanning of up to 31 distributed I/O systems.



The CI865 supports on line replacement (Hot Swap), and does not require any configuration before installation. CI865 cannot be used in a High Integrity controller.

For more information see *AC 800M Interfacing SATT I/O (3BSE042821\*)*.

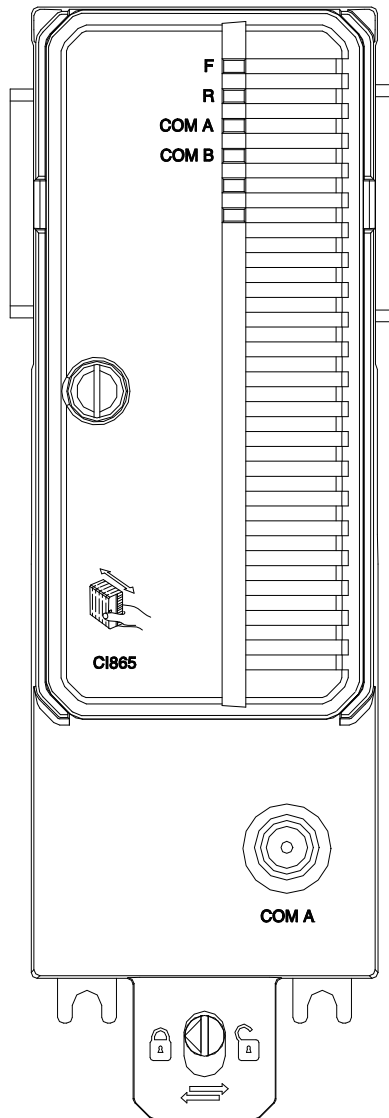

Figure 34. SATT I/O Communication Interface

## Modbus TCP Interface - CI867

The CI867/TP867 is used for connection between an AC 800M controller and external Ethernet devices using Modbus TCP protocol.

The TP867 Baseplate has two RJ45 Ethernet connectors, where Ch1 connector can use 10Mbps or 100Mbps (Mega bits/sec.) and Ch2 use 10Mbps only. The baseplate has a code lock, that prevents the installation of an incorrect type of unit onto the TP867 Baseplate.

The CI867 expansion unit contains the CEX-Bus logic, a communication unit and a DC/DC converter that supplies appropriate voltages from the +24 V supply via the CEX-Bus. The Ethernet cable must be connected to the main network through an Ethernet switch.

The CI867 can be set redundant and supports hot swap.

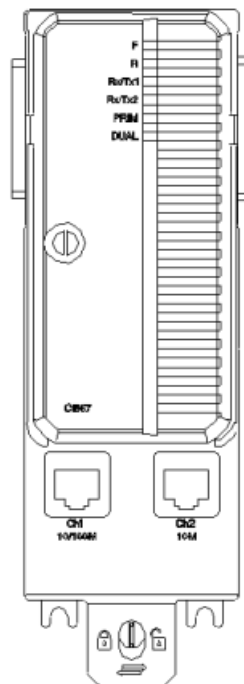

Figure 35. Modbus TCP Interface

## IEC 61850 Interface - CI868

The CI868 can be used to connect an AC 800M controller to external Ethernet devices using IEC 61850 protocol.

The TP868 Baseplate has two RJ45 Ethernet connectors, where CH1 connector can use 10Mbps or 100Mbps (Mega bits/sec.). The baseplate has a code lock that prevents the installation of an incorrect type of unit onto the TP867 Baseplate.

The CI868 expansion unit contains the CEX-Bus logic, a communication unit and a DC/DC converter that supplies appropriate voltages from the +24 V supply via the CEX-Bus. The Ethernet cable must be connected to the main network through an Ethernet switch.

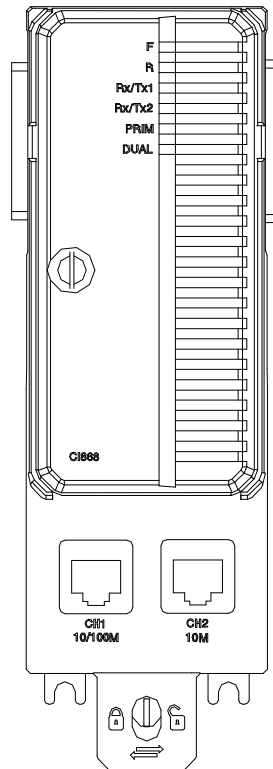

Figure 36. IEC 61850 Interface

## AF 100 Interface - CI869

The CI869 is an AC 800M communication interface that connects to the AF 100 field bus through the twisted pair (TWP).

The CI869 expansion unit contains the CEX-Bus logic, a communication unit, and a DC/DC converter that supplies the required voltage from +24 V supply through the CEX-Bus.

The CI869 can be configured for both redundant cables and redundant communication interfaces. For details about the operation and configuration of CI869 connected to AF 100 bus, refer to *Advant Fieldbus 100 User Manual (3BSE000506\*)*.

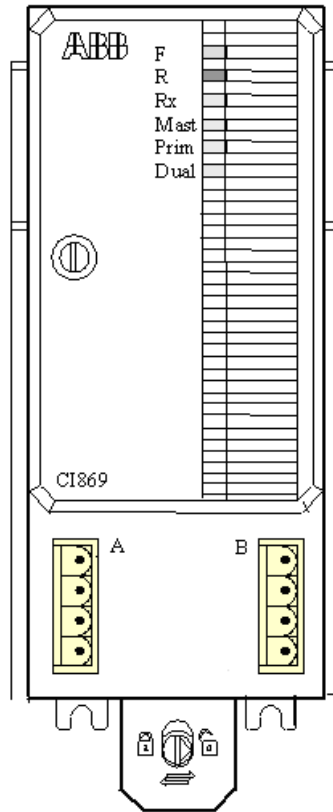

Figure 37. AF 100 communication interface - CI869

## **PROFINET IO Interface - CI871**

The CI871 is an AC 800M communication interface that connects to the PROFINET IO devices through Ethernet.

The TP867 Baseplate has two RJ45 Ethernet connectors, but only the CH1 connector that supports 100Mbps is used for PROFINET IO connection.

The Ethernet cable must be connected to the PROFINET IO network through an Ethernet switch.

The CI871 expansion unit contains the CEX-Bus logic, a communication unit, and a DC/DC converter that supplies the required voltage from +24 V supply through the CEX-Bus.



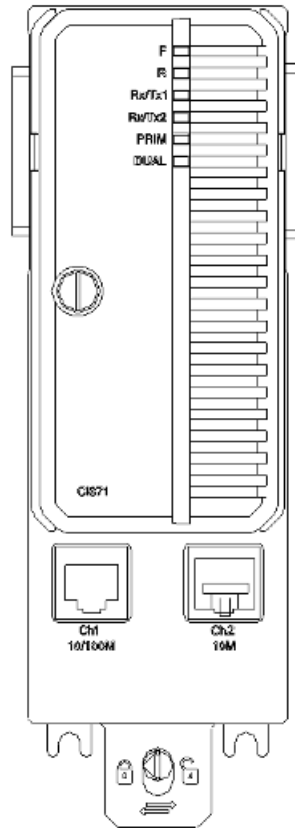

Figure 38. PROFINET IO communication interface - CI871

## EtherNet/IP Interface - CI873

The CI873 is an AC 800M communication interface that connects to external Ethernet devices using the EtherNet/IP protocol.

The TP867 Baseplate has two RJ45 Ethernet connectors, but only the CH1 connector that supports 100Mbps is used.

The CI873 expansion unit contains the CEX-Bus logic, a communication unit, and a DC/DC converter that supplies the required voltage from +24 V supply through the CEX-Bus.

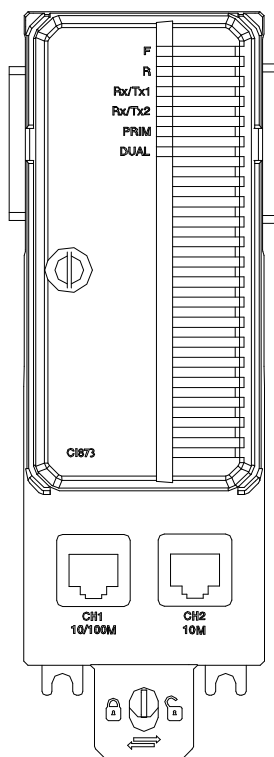

Figure 39. EtherNet/IP communication interface - CI873

## Battery Back-up

### Internal Battery

The internal battery is located under a removable cover on the processor unit, see [Figure 6](#) on page 33.



The internal battery is not available for PM891.

### External Battery SB821

If a longer memory back-up time is required, the external battery unit SB821 can be used. The external battery unit is mounted on the DIN rail and connected to the CPU, via a cable.

The batteries used in SB821 and internal battery are of the non-rechargeable Lithium type. Hence the battery need to be replaced after any system commissioning phase, several system power-downs or after any lengthy continuous power failure. This should be done in order to sustain the specified battery back-up time.

### Rechargeable External Battery SB822

If a rechargeable battery backup option is desired, the rechargeable external battery unit SB822 can be used. The external battery unit is mounted on the DIN rail and connected to the CPU, via a cable. The charger is connected to 24V DC supply.

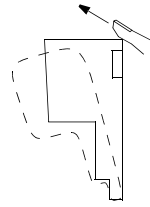

SB822 is the only external battery available for PM891.

<p>SB821 3.6V Lithium Battery Unit</p> <p> Note the warning text on the battery.</p> <p>X1</p> <p>B- B+ SH</p>	
---	--

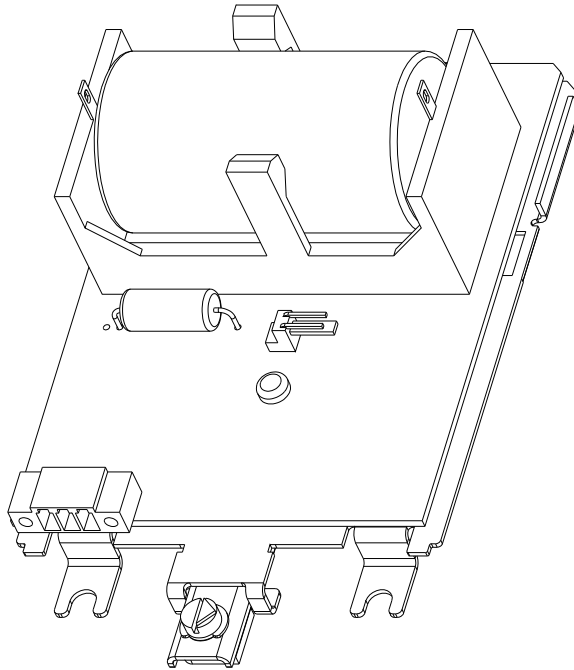

Figure 40. SB821 External Battery Unit - Cover Removed

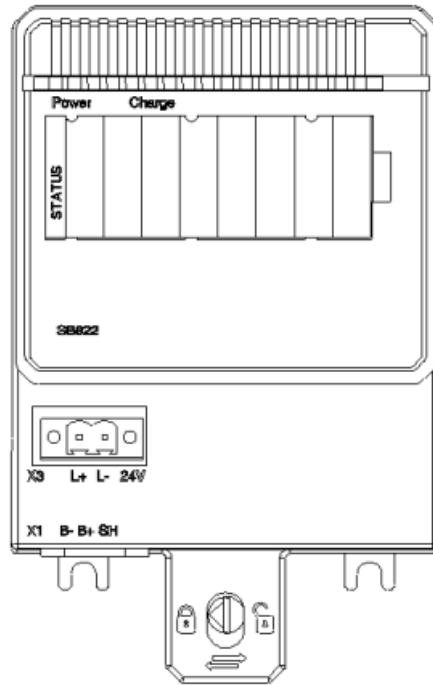

Figure 41. SB822 External Rechargeable Battery Unit

## Power Supply Components - SD83x and SS832

### Power Supply Units - SD831, SD832, SD833, and SD834

These four PSUs are designed as switch mode power converters. They convert a.c. or d.c. mains supply voltage to a regulated d.c. 24 V output. The four PSUs have data as follows:

- SD831 = Input a.c. 100-240 V or d.c. 110-300 V.  
Output d.c. 24 Volts regulated @ 3 A.
- SD832 = Input a.c. 100-120 or 200-240 V.  
Output d.c. 24 Volts regulated @ 5 A
- SD833 = Input a.c. 100-120 or 200-240 V.  
Output d.c. 24 Volts regulated @ 10 A
- SD834 = Input a.c. 100-240 V or d.c. 110-300 V.  
Output d.c. 24 Volts regulated @ 20 A

The output voltage of the four PSUs is, as stated, a regulated, low noise, d.c. 24 V. A LED, mounted on the PSU front panel indicates that the output voltage is within range.

The PCS's provide a soft start feature. The controlled power-on of a PSU therefore, will not trip fuses or earth-fault circuit breakers. In addition, the normal disturbances that occur within an industrial main network will not cause any transient fault conditions or trips to occur.

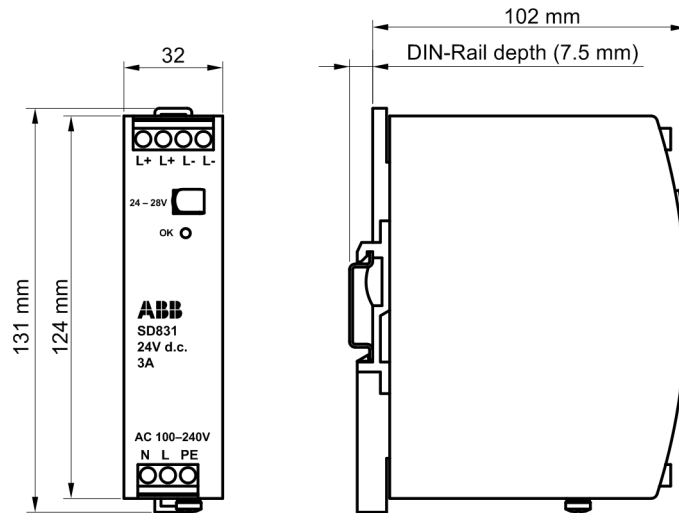

Figure 42. SD831 Dimension and Connections for 3 A Power Supply

### SS823 Voting Unit

The SS823 Voting Unit has double overvoltage protection circuit on the input. It is also able to detect both short and open circuit in the voting element.



Please note that for voting two SS823 is required.

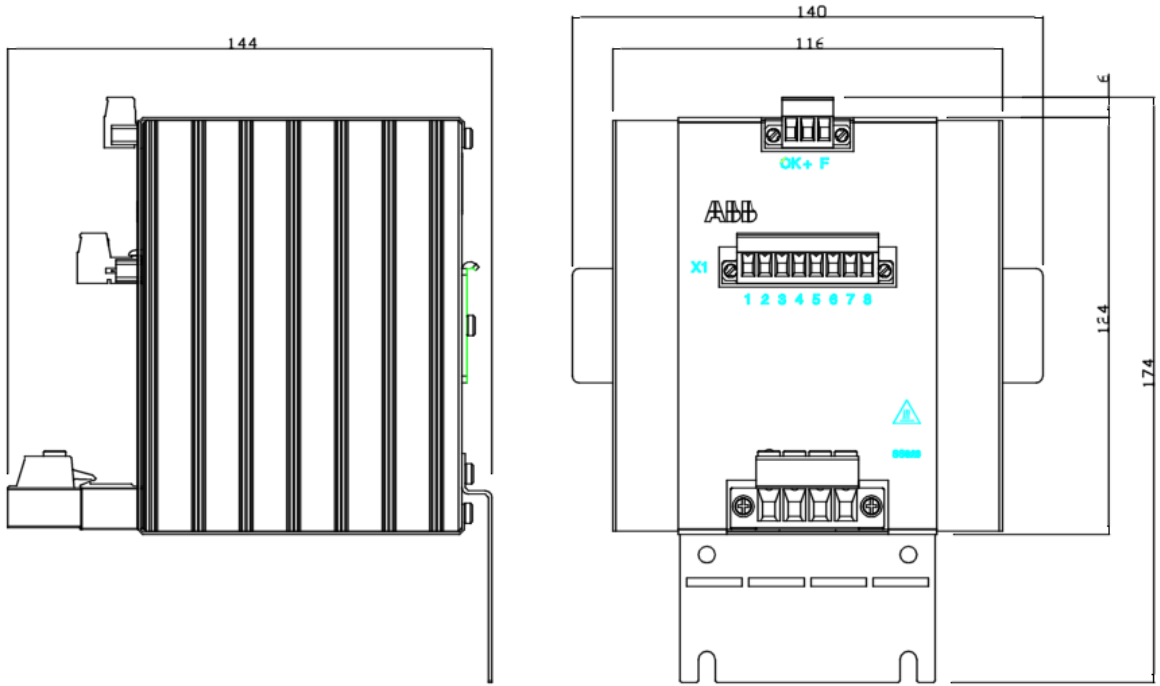

Figure 43. SS823 Voting Unit Connections



**SS832 Voting Unit**

SS832 voting unit is can be used directly for load up to 10 A. For loads up to 20 A, two SS832 modules must be used.

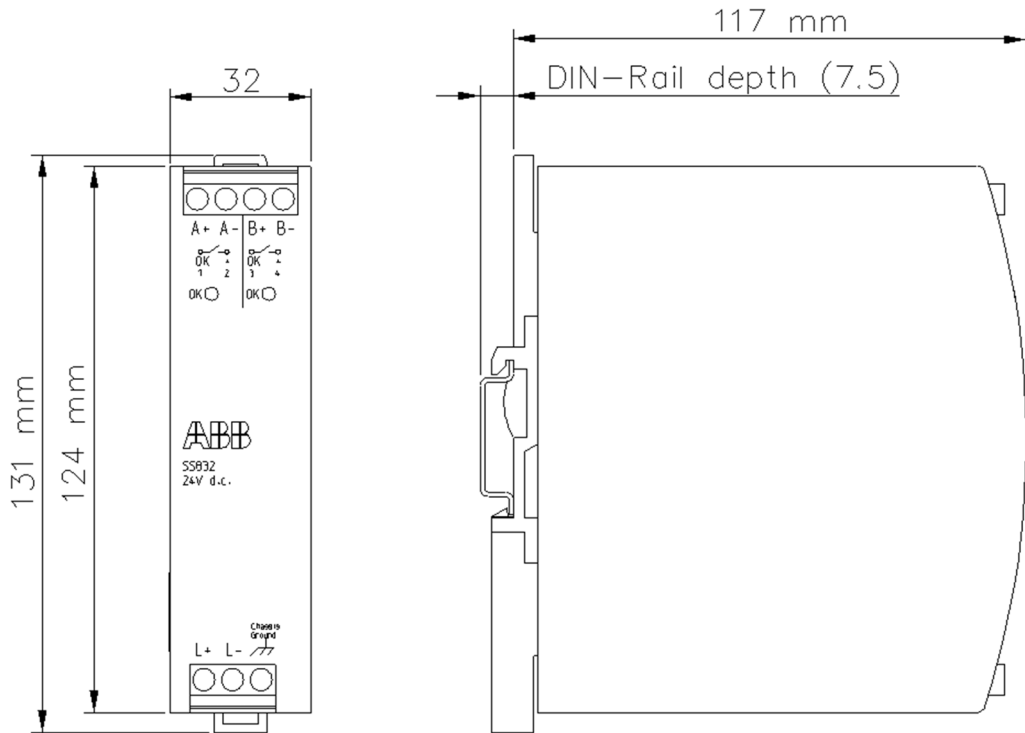

Figure 44. SS832 Voting Unit Dimensions and Connections

## Mounting Rails

All units, comprising the AC 800M Controller, are mounted onto DIN rails (type: TS 35/7.5). However, the DIN rail itself is not rigid enough to support the units on its own. Therefore, a support, such as an Al-profile, which has been specifically designed for supporting DIN rails, is required, (see [Figure 45](#) on page 106). Refer to price list for additional information.

The key features of the Al-profile are:

- Simple mounting features.
- No drilling required, profile incorporates pre-formed channels suitable for self-tapping screws.
- Provides secure mounting in locations subject to extreme vibration, see [Figure 16](#) on page 51.
- Provides good grounding support
- Rigid, non-flexible construction.
- Easy fit, press-in cable retaining duct.

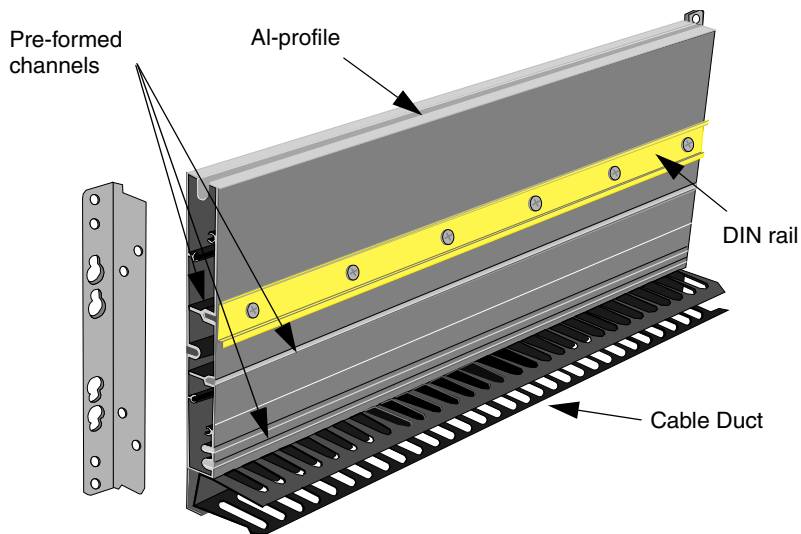

*Figure 45. DIN Rail Mounted on an Al-Profile*

## CEX-Bus Extension and Termination

A TB850 CEX-Bus terminator must always be installed on the last unit on the CEX bus, as shown in [Figure 46](#) on page 107 and [Figure 47](#) on page 108. A CEX-Bus terminator is supplied with each PM8xx single configuration processor unit.

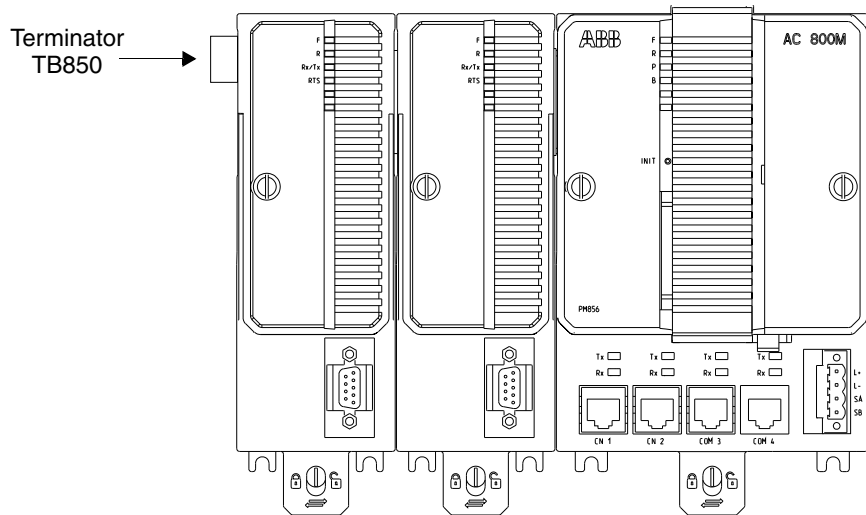

Figure 46. TB850 Terminator for CEX-Bus (Male)

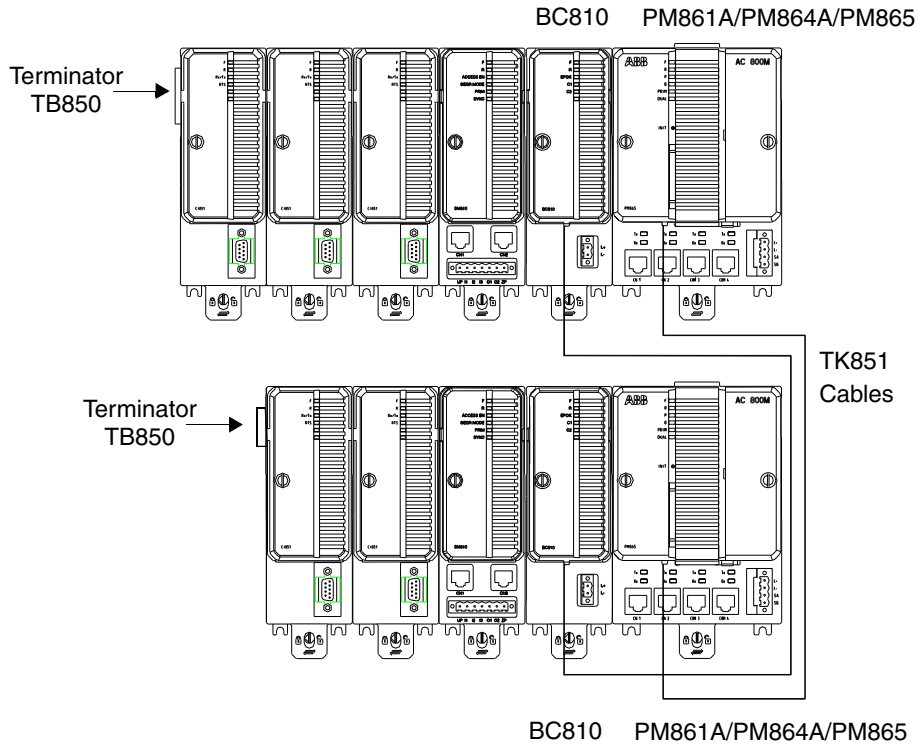

Figure 47. CEX-Bus Terminator when using Redundant Communication Interface Units (with BC810) and Controllers

When Communication Interface units are mounted on adjacent DIN rails, they are connected by means of a CEX-Bus extension cable (TK850) and terminated using a TB851 CEX-Bus terminator, as shown in Figure 48 on page 109. However, only one TK850 CEX-Bus extension cable may be used in any one CEX-Bus.

The CEX-Bus extension cable, TK850, is also used in redundant CPU configuration, see Figure 19 on page 61. The cable length is 0.7m (2.3 feet).

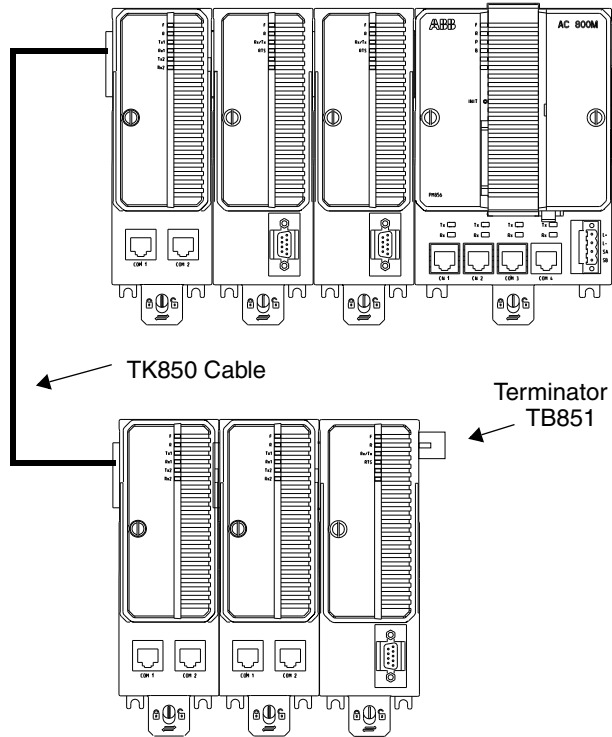

Figure 48. TB851 Terminator for CEX-Bus (Female)

## ModuleBus Extension and Termination

A terminator, TB807, must always be mounted on the last I/O-unit on the ModuleBus. A ModuleBus terminator is delivered with the PM8xx processor unit.

For additional information about the ModuleBus, refer to the Product Guide for S800 I/O.

## RCU Link Cable and Termination

### TB852 RCU Link Terminator Plug

The TB852 RCU Link Terminator Plug is required when the processor unit PM861/PM864/PM865/PM866 operates in single configuration. This is plugged to the RCU Link port on the processor unit.

### TB853 RCU Control Link Terminator Plug

The TB853 RCU Control Link Terminator Plug is required when the PM891 processor unit operates in single configuration. This is plugged to the RCU Control port at the top of the PM891 unit.

### TK851 RCU Link Cable for PM86x

The Redundant Control Unit Link Cable, TK851, is used to transfer log data from the Primary CPU to the Backup CPU and to exchange status and control information between the Primary and the Backup CPUs, see [Figure 19](#) on page 61. The RCU Link uses 68-pole connectors. One of the connectors has a label marked “UPPER”. The CPU connected to this connector will be defined as the upper CPU in the Control Builder and Operator Station.

The RCU Link Cable is also used as interconnection cable between two BC810 modules.

### TK855 RCU Data Link Cable for PM891

The TK855 Redundant Control Unit Data Link Cable, connected between redundant PM891 units, transfers the data required to keep the backup PM891 synchronized with the primary PM891.

## **TK856 RCU Control Link Cable for PM891**

The TK856 Redundant Control Unit Control Link Cable, connected between redundant PM891 units, provides role selection and CPU identity assignment (UPPER/LOWER).





---

## Section 5 Mechanical Design

### Cabinet Design

The figures listed below are examples of how the AC 800M Controllers, Power Supply units, Voting units and S800 I/O units can be configured and mounted within cabinets:

- [Figure 49](#) on page 114, Wall Cabinet - Single Power Supply Arrangement
- [Figure 50](#) on page 115, Wall Cabinet - Dual Power Supply (Local/Field) Arrangement
- [Figure 51](#) on page 116, Floor Mounted Cabinet - Unit Arrangement (Redundant PSU)

The DIN-rails are using the supporting Al-profile to ensure rigidity. See [Figure 45](#) on page 106.

The cabinets shown in the figures are ABB manufactured cabinets:

- RE820      Wall Cabinet
- RM550      Floor Cabinet

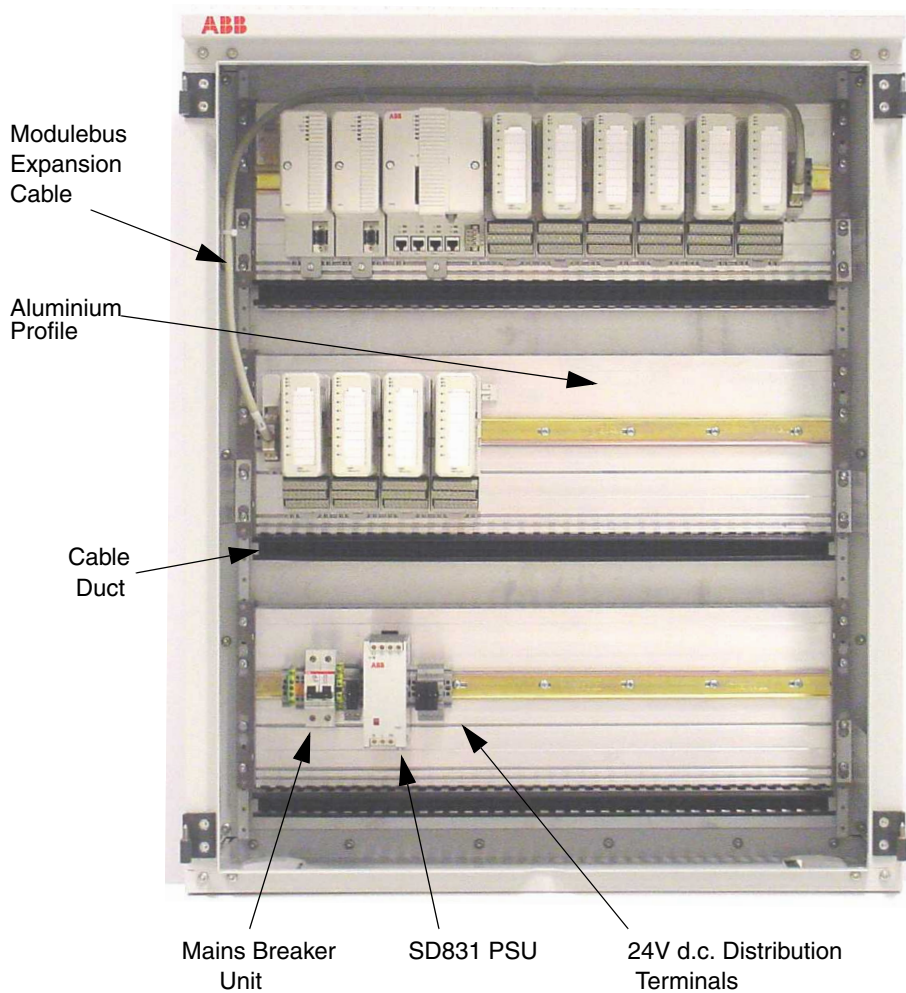

Figure 49. Wall Cabinet - Single Power Supply Arrangement

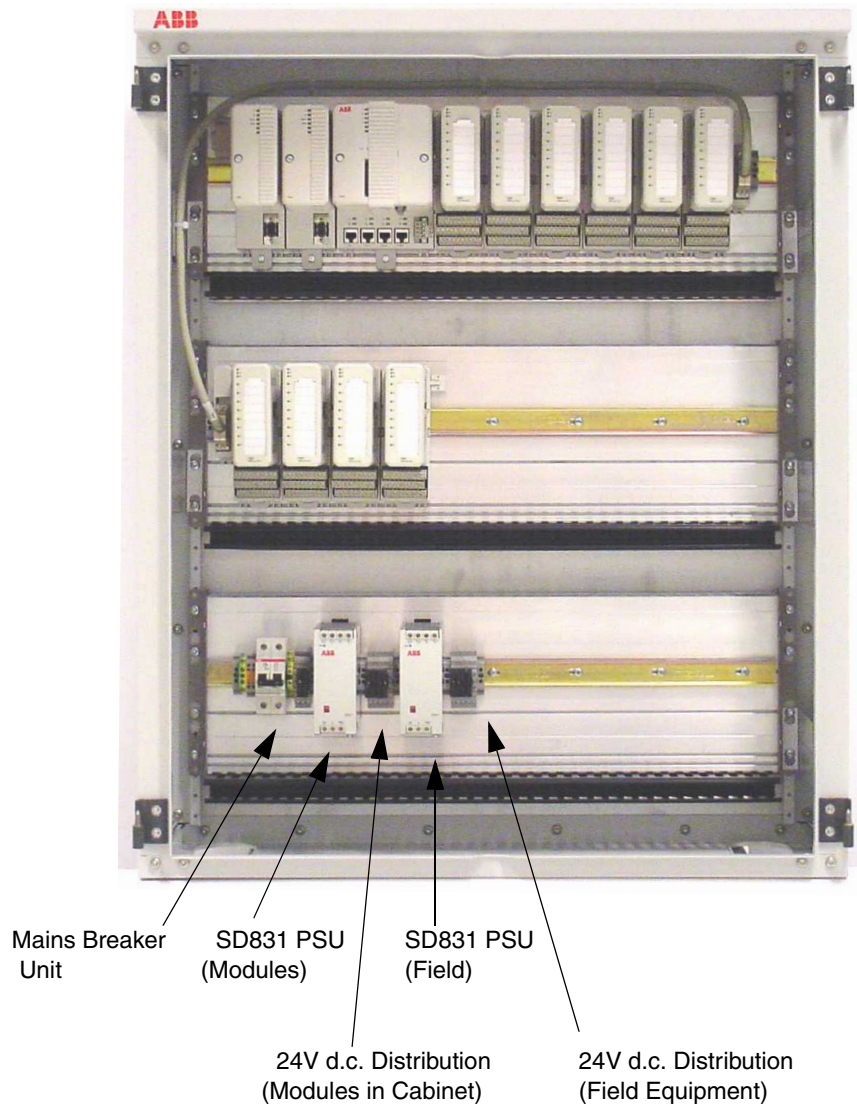

Figure 50. Wall Cabinet - Dual Power Supply (Local/Field) Arrangement

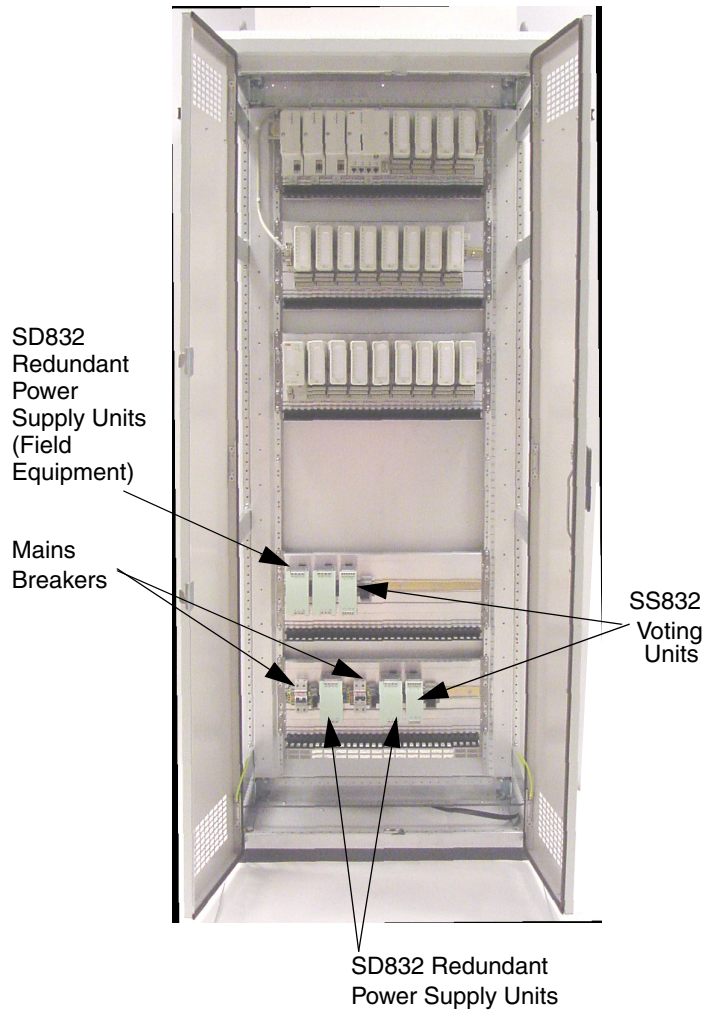

Figure 51. Floor Mounted Cabinet - Unit Arrangement (Redundant PSU)

## Mounting Dimensions for Proper Ventilation

To maintain cooling airflow through the AC 800M Controller units, no obstructions must be placed within 50 mm (2") above and 25 mm (1") below the units, as shown in Figure 52 on page 117. **Note** that the CPU and communication interfaces must be mounted on a **horizontal** DIN rail.

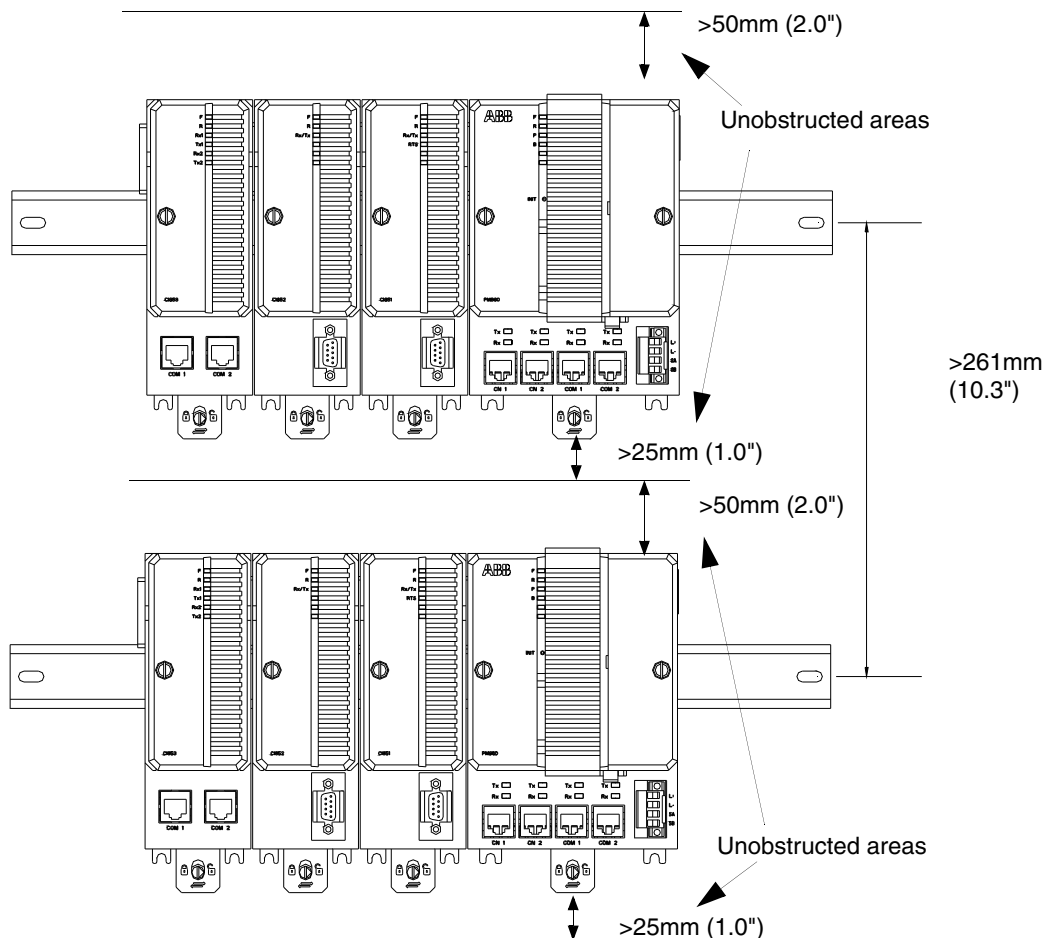

Figure 52. Ventilation Requirements - Minimum Mounting Dimensions



---

## Section 6 Technical Data and Performance

### General

Technical data or performance specification missing in this manual might be found in the System Guide Technical Data and Configuration Information (3BSE041434\*).

### Processor Unit - PM8xx and TP830

#### Performance Data for PM851/PM856 and PM860

The processor units PM851/PM856/PM860 differ only in performance when executing an application program.

Using the same application program in PM851/PM856 and PM860, the execution in PM860 is twice as fast as in PM851/PM856.

#### Performance Data for PM851A/PM856A and PM860A

The processor units PM851A/PM856A/PM860A differ in the available RAM and in the performance when executing an application program.

Using the same application program in PM851A/PM856A and PM860A, the execution in PM860A is twice as fast as in PM851A/PM856A.

#### Performance Data for PM861/PM864/PM865/PM866

The PM861 processor unit, in single configuration, has the same performance data as the PM860. In redundant configuration the execution performance is somewhat lower than in single configuration.

The PM864/PM865 processor unit, in single configuration, has performance data which theoretically peaks at twice the performance compared to the PM860. The useful sustained performance improvement is, however, a bit lower and somewhat dependent on the actual application program but can be expected to be 10 to 50% compared to PM860. In redundant configuration the execution performance is somewhat lower than in single configuration.

Performance of the PM866 processor unit is 1.4 times the performance of PM864.



PM865 is designed for use in a High Integrity controller. If it is run as a non-SIL controller without any SIL applications, its performance will be the same as stated above, while performance will be lower when running SIL applications.

### Performance Data for PM891

The PM891 processor unit has performance data approximately three times the performance of PM864. In redundant configuration too, the execution performance is approximately three times the performance of PM864.

Switch over time from Primary CPU to Backup CPU, in redundant CPU configuration, is less than 10 ms.



Table 4. Processor Unit - PM8xx and TP830

Item	Value
CPU	<ul style="list-style-type: none"> <li>• <b>PM851/PM851A/PM856/PM856A/PM860/PM860A/PM861</b> MPC860 Microprocessor running at 48 MHz.</li> <li>• <b>PM864/PM865</b> MPC862 Microprocessor running at 96 MHz.</li> <li>• <b>PM866</b> MPC866 Microprocessor running at 133 MHz.</li> <li>• <b>PM891</b> MPC8270 Microprocessor running at 450 MHz.</li> </ul>
Memory	<ul style="list-style-type: none"> <li>• <b>PM851/PM856/PM860</b> 2 MBytes flash PROM (firmware storage). 8 MBytes SDRAM</li> <li>• <b>PM851A</b> 2 MBytes flash PROM (firmware storage). 12 MBytes SDRAM</li> <li>• <b>PM856A/PM860A</b> 2 MBytes flash PROM (firmware storage). 16 MBytes SDRAM</li> <li>• <b>PM861</b> 2 MBytes flash PROM (firmware storage). 16 MBytes SDRAM</li> <li>• <b>PM864</b> 2 MBytes flash PROM (firmware storage). 32 MBytes SDRAM</li> </ul>

Table 4. Processor Unit - PM8xx and TP830 (Continued)

Item	Value
Memory (Continued)	<ul style="list-style-type: none"> <li>• <b>PM865</b> 4 MBytes flash PROM (firmware storage). 32 MBytes SDRAM</li> <li>• <b>PM866</b> 4 MBytes flash PROM (firmware storage). 64 MBytes SDRAM</li> <li>• <b>PM891</b> 16 MBytes flash PROM (firmware storage) 256 MBytes of DDR2 SDRAM with integrity check</li> </ul>
Internal Battery	<p>Lithium Battery 3.6 V, 950 mAh. Battery memory back up time is:</p> <ul style="list-style-type: none"> <li>• <b>PM851/PM856/PM860</b> a minimum of 48 hours.</li> <li>• <b>PM851A/PM856A/PM860A</b> a minimum of two weeks.</li> <li>• <b>PM861/PM864</b> a minimum of 36 hours.</li> <li>• <b>PM861A</b> a minimum of 118 hours.</li> <li>• <b>PM864A/PM865</b> a minimum of 235 hours.</li> <li>• <b>PM866</b> a minimum of 158 hours.</li> </ul>

Table 4. Processor Unit - PM8xx and TP830 (Continued)

Item	Value
External Battery Unit SB821	Lithium battery 3.6V 16Ah. Battery memory back-up time is: <ul style="list-style-type: none"> <li>• <b>PM851/PM856/PM860</b> a minimum of 4 weeks.</li> <li>• <b>PM851A/PM856A/PM860A</b> a minimum of 8 months.</li> <li>• <b>PM861/PM864</b> a minimum of 3 weeks.</li> <li>• <b>PM861A</b> a minimum of 12 weeks</li> <li>• <b>PM864A/PM865</b> a minimum of 24 weeks.</li> <li>• <b>PM866</b> a minimum of 15 weeks.</li> </ul>
Rechargeable battery unit SB822	Lithium battery, 3.75 V 2.4 Ah. Battery memory back-up time, when fully charged is: <ul style="list-style-type: none"> <li>• <b>PM851/PM856/PM860</b> a minimum of 100 hours.</li> <li>• <b>PM851A/PM856A/PM860A</b> a minimum of 4 weeks.</li> <li>• <b>PM861/PM864</b> a minimum of 85 hours.</li> <li>• <b>PM861A</b> a minimum of 285 hours.</li> <li>• <b>PM864A/PM865</b> a minimum of 3 weeks.</li> <li>• <b>PM866</b> a minimum of 16 days.</li> <li>• <b>PM891</b> a minimum of 33 hours</li> </ul>

Table 4. Processor Unit - PM8xx and TP830 (Continued)

Item	Value
Unit Size and Weight	<p><b>PM8xx (except PM891):</b></p> <p>Width (measured along DIN rail):</p> <ul style="list-style-type: none"> <li>• 119 mm (4.7") (Note: When not mounted, CEX bus contact protrudes an additional 4 mm (0.16"))</li> </ul> <p>Depth (measured from wall):</p> <ul style="list-style-type: none"> <li>• 135 mm (5.3")</li> </ul> <p>Height (measured vertically, inclusive of locking device):</p> <ul style="list-style-type: none"> <li>• 186 mm (7.3")</li> </ul> <p>Weight:</p> <ul style="list-style-type: none"> <li>• 1100 g (2.4 lb) (package PM851K01 and PM851AK01)</li> <li>• 1100 g (2.4 lb) (package PM856K01 and PM856AK01)</li> <li>• 1100 g (2.4 lb) (package PM860K01 and PM860AK01)</li> <li>• 1200 g (2.6 lb) (package PM861K01, PM864K01, PM866K01, and PM865K01)</li> <li>• 2800 g (6.1 lb) (package PM861K02, PM864K02, PM866K02, and PM865K02)</li> </ul> <p>All packages incl. TP830 and bus terminations</p> <p><b>PM891:</b></p> <p>Width (measured along DIN rail):</p> <ul style="list-style-type: none"> <li>• 200 mm (7.9")</li> </ul> <p>Depth (measured from wall):</p> <ul style="list-style-type: none"> <li>• 102 mm (4.0")</li> </ul> <p>Height (measured vertically, inclusive of locking device):</p> <ul style="list-style-type: none"> <li>• 186 mm (7.3")</li> </ul> <p>Weight: 1.6 kg (1.9 kg with package)</p>

Table 4. Processor Unit - PM8xx and TP830 (Continued)

Item	Value
Protective Rating	IP20 according to EN60529, IEC 529.
Port CN1, CN2 Connector: RJ45 (Only CN1 for PM851/PM851A)	Ethernet Communication: Communication speed, 10 Mbit/s (half duplex) Signal levels, IEEE802.3, 10 Base T <b>PM891:</b> CN1 + CN2 (built in, 10/100Mbit/s), Ethernet ports (IEEE 802.3u, 10 Base-T/100Base-Tx).
Port COM3 Connector: RJ45	COM3, Serial Communication: Communication speed selectable in steps from 75 to 19200 baud. 75, 110, 134.5, 150, 300, 600, 1200, 1800, 2000, 2400, 9600, 19200 baud. Signal levels, RS-232C Full modem support <b>Protocol specific restrictions apply.</b> <b>PM891 does not have a COM3 port.</b>
Port COM4 Connector: RJ45	COM4, Serial Communication to Control Builder Communication speed 9600 baud Signal levels, RS-232C
Electrical ModuleBus	I/O capacity 1 S800 I/O base cluster with up to 12 S800 I/O-units with a total of up to 192 S800 I/O-signals. <b>PM891 does not have an electrical ModuleBus</b>

Table 4. Processor Unit - PM8xx and TP830 (Continued)

Item	Value
Optical ModuleBus	I/O capacity 7 S800 I/O clusters each with 12 units totaling up to 1344 I/O-signals. (One S800 I/O cluster for PM851/PM851A) <b>PM891:</b> Max of 7 S800 I/O clusters with twelve non-redundant or six redundant modules (i.e. 7x12 = 84 modules). Redundant and non-redundant modules can be mixed.
CEX-Bus	Max. 12 communication interfaces, in any configuration, can be connected. (Max. one CEX module for PM851/PM851A)
Supply Current and Fuses for Buses	<b>ModuleBus</b> Maximum supply current 1 A. @ 24 V Fuse 2 A (fast). Maximum supply current 1.5 A @ 5 V <b>CEX-Bus</b> Maximum supply current 2.4 A. @ 24 V Fuse 3.15 A (fast). See <a href="#">Figure 53</a> on page 129
Redundant Power Supply Status	Inputs designated SA, SB Max input voltage 30 V d.c. Min. input voltage for high level 15 V d.c. Max input voltage for low level 8 V d.c.
Supply Requirements	Supply voltage (L+, L-), 24 V d.c. Allowed variation, 19.2 - 30 V d.c.

Table 4. Processor Unit - PM8xx and TP830 (Continued)

Item	Value
Current Consumption 24V (excl. ModuleBus and CEX-Bus).	<ul style="list-style-type: none"><li data-bbox="687 346 1240 440">• <b>PM851/PM851A/PM856/PM856A/PM860/PM860A</b> typical 180 mA.</li><li data-bbox="687 449 925 514">• <b>PM861</b> typical 250 mA.</li><li data-bbox="687 522 925 587">• <b>PM864/PM865</b> typical 287 mA.</li><li data-bbox="687 596 925 660">• <b>PM866</b> typical 210 mA.</li><li data-bbox="687 669 925 732">• <b>PM891</b> typical 660 mA.</li></ul>

Table 4. Processor Unit - PM8xx and TP830 (Continued)

Item	Value
Power Loss (Heat) (with full load of I/O and CEX-Bus units).	<ul style="list-style-type: none"> <li>• <b>PM851/PM851A</b> typical 8.5 W, Max.11 W.</li> <li>• <b>PM856/PM856A/PM860/PM860A</b> typical 10 W, Max.13 W.</li> <li>• <b>PM861</b> typical 11 W, Max. 15.3 W.</li> <li>• <b>PM864/PM865</b> typical 11.9 W, Max. 16.4 W.</li> <li>• <b>PM866</b> typical 10.1 W, Max. 13.6 W.</li> <li>• <b>PM891</b> Typical 15.8 W, Max. 18 W</li> </ul>
Certification	<ul style="list-style-type: none"> <li>• <b>PM851/PM851A/PM856/PM856A/PM860/ PM860A with TP830</b> UL508 and UL60079-15 Hazardous location Class 1 Zone 2</li> <li>• <b>PM861/PM864 with TP830</b> UL508 and UL60079-15 Hazardous location Class 1 Zone 2</li> <li>• <b>PM861A/PM864A/PM865</b> UL508 and UL60079-15 Hazardous location Class 1 Zone 2</li> <li>• <b>PM866 with TP830</b> UL508 and UL60079-15 Hazardous location Class 1 Zone 2</li> <li>• <b>PM891</b> UL listing pending</li> </ul>



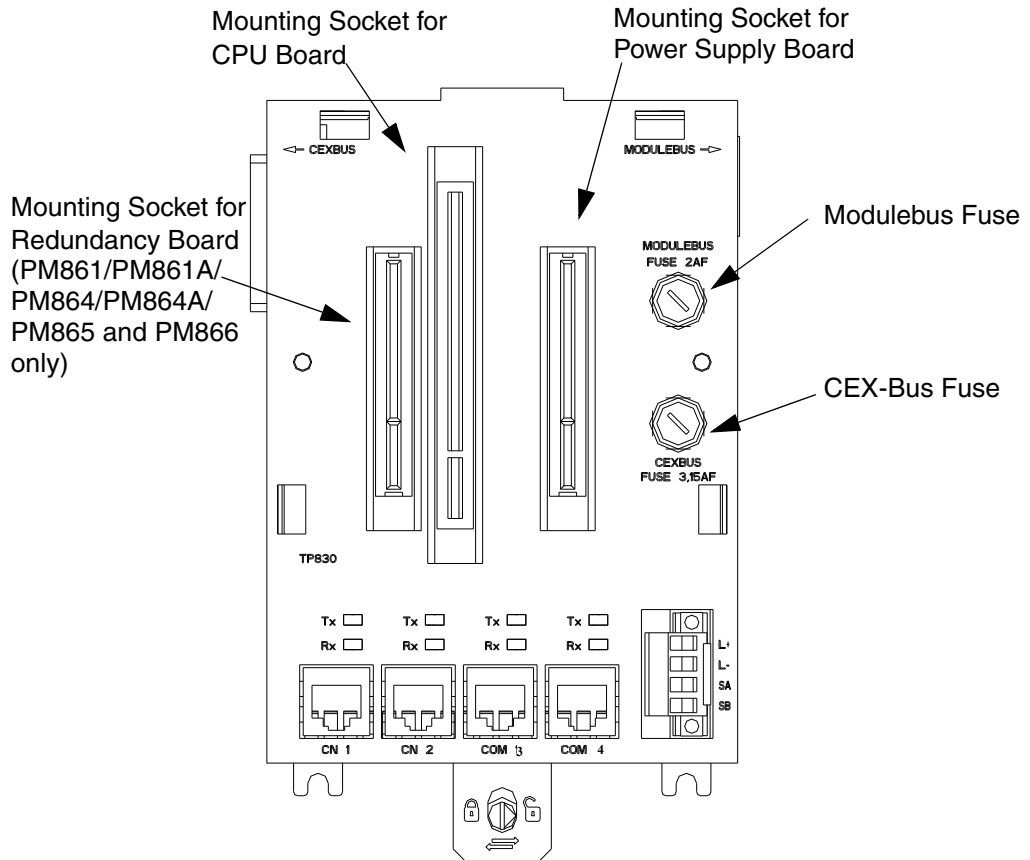

Figure 53. TP830 Base plate - Mounting Sockets and Fuses

## CEX-Bus Interconnection Unit - BC810 and TP857

Table 5. CEX-Bus Interconnection Unit - BC810

Item	Value
Status Indicators	Red LED for error Green LED for run Green LED for external power OK Two yellow LEDs for traffic
Power Input Connector	Two pin, screw connector L+, L-.
Power Supply Requirements	Inputs designated L+ and L- 24 V nominal, variation between 19.2 V DC and 30 V DC.
Current consumption	50 mA typical (70 mA max)
Power dissipation	1.2 W typical
Protection Rating	IP20 according to EN60529, IEC 529
Weight	700 g (1.5 lb) (package BC810K01)
Dimensions	W 59 x H 185 x D 127.5 mm (W 2.9 x H 7.3 x D 5.0 in)
Certification	UL508 and UL60079-15 Hazardous location Class 1 Zone 2
Hot swap	Supported

## SM810 and TP855

Table 6. SM810

Item	Value
Memory	<ul style="list-style-type: none"> <li>4 MB flash PROM (firmware storage).</li> <li>32 MB of SDRAM</li> </ul>
Galvanic isolation	Yes
Status Indicators	Red LED for error Green LED for run Two yellow LEDs for future use Yellow LED for primary Yellow LED for synchronization
Connector	One 7 pin screw connector
Current consumption (from CEX-Bus 24 V DC)	160 mA typical (250 mA max)
Power dissipation	3.8 W typical
Hot Swap	Hot Swap of backup SM810 in redundant configuration is supported
Weight	700 g (1.5 lb) (package SM810K01 with SM810 and TP855).
Dimensions	W 59 x H 185 x D 127.5 mm (W 2.9 x H 7.3 x D 5.0 in)
Certification	UL508 and UL60079-15 Hazardous location Class 1 Zone 2

## SM811 and TP855

Table 7. SM811

Item	Value
Memory	<ul style="list-style-type: none"> <li>4 MB flash PROM (firmware storage).</li> <li>32 MB of SDRAM</li> </ul>
Galvanic isolation	Yes
Status Indicators	Red LED for error Green LED for run Two yellow LEDs for future use Yellow LED for primary Yellow LED for synchronization
Connector	One 7 pin screw connector
Current consumption (from CEX-Bus 24 V DC)	160 mA typical (250 mA max)
Power dissipation	3.8 W typical
Hot Swap	Hot Swap of backup SM811 in redundant configuration is supported
Weight	700 g (1.5 lb) (package SM811K01 with SM811 and TP868).
Dimensions	W 59 x H 185 x D 127.5 mm (W 2.9 x H 7.3 x D 5.0 in)
Certification	UL508 and UL60079-15 Hazardous location Class 1 Zone 2

## PROFIBUS DP Interface - CI851 and TP851



CI851 cannot be used in an AC 800M High Integrity controller.

*Table 8. PROFIBUS DP Interface - CI851 and TP851*

Item	Value
Type	DP Master Class I
Protocol	PROFIBUS DP
Communication speed	9.6, 19.2, 93.75, 187.5, 500, 1500, 3000, 6000, or 12000 kbit/s
Bus Capacity (one segment)	Max 32 nodes
Galvanic Isolation	Yes
Status Indicators	Red LED for error Green LED for run Yellow LED for traffic
Connector	DB9, female on TP851
Current Consumption from CEX-Bus 24 V d.c.	Typical 150 mA
Power Dissipation	3.6 W typical
Weight	700 g (1.5 lb) (package CI851K01)
Dimensions	W 59 x H 185 x D 127.5 mm (W 2.3 x H 7.3 x D 5.0 inches)
Protective Rating	IP20 according to EN60529, IEC 529.
Certification	UL508 and UL60079-15 Hazardous location Class 1 Zone 2
Hot swap	Not supported

## RS-232C Interface - CI853 and TP853

Table 9. CI853 - RS-232C Communication Interface Specifications

Item	Description
Type	Double unisolated RS-232C ports with Hayes modem signals. <b>Protocol specific restrictions may apply.</b>
Number of Channels	2 channels
Protocol	Determined by software, application and licenses. Intended for Modbus, Siemens 3964R, COMLI and custom designed protocols.
Communication speed	Selectable in steps from 75 to 19200 baud. 75, 110, 134.5, 150, 300, 600, 1200, 1800, 2000, 2400, 9600, 19200 baud. <b>Protocol specific restrictions apply.</b>
Galvanic Isolation	Non-isolated
Status Indicators	Red LED for error Green LED for run Yellow LED for traffic
Connector	Two RJ45 connectors on TP853
Current Consumption	Typical 100 mA
Power Dissipation	2.4 W typical
Weight	700 g (1.5 lb) (package CI853K01)
Dimensions	W 59 x H 185 x D 127.5 mm (W 2.9 x H 7.3 x D 5.0 inches)
Protective Rating	IP20 according to EN60529, IEC 529.
Certification	UL508 and UL60079-15 Hazardous location Class 1 Zone 2
Hot swap	Supported

## PROFIBUS DP Interface - CI854/CI854A and TP854

Table 10. PROFIBUS DP Interface - CI854/CI854A and TP854

Item	Value
Type	DP Master Class 1 and 2 for DP-V0 Services DP Master Class II for DP-V1 Services
Protocol	PROFIBUS DP
Communication speed	9.6, 19.2, 93.75, 187.5, 500, 1500, 3000, 6000, or 12000 kbit/s
Bus Capacity (one segment)	Max 32 nodes
Galvanic Isolation	Yes
Status Indicators	Red LED for error Green LED for run Yellow LED for traffic Yellow LED for primary (CI854A only) Yellow LED for dual mode (CI854A only)
Connector	two DB9, female on TP854
Current Consumption from CEX-Bus 24 V d.c.	Typical 190 mA (max. 240 mA)
Power Dissipation	4.6 W typical
Weight	700 g (1.5 lb) (package CI854K01)
Dimensions	W 59 x H 185 x D 127.5 mm (W 2.3 x H 7.3 x D 5.0 inches)
Protective Rating	IP20 according to EN60529, IEC 529.
Certification	UL508 and UL60079-15 Hazardous location Class 1 Zone 2
Hot swap	Supported for CI854A Not supported for CI854

## MasterBus 300 Interface - CI855 and TP853

Table 11. MasterBus 300 Interface - CI855 and TP853

Item	Value
Type	Ethernet unit Signal levels, IEEE802.3, 10 Base T
Protocol	MasterBus 300, dataset
Communication speed	10 Mbit/s (half duplex)
Status Indicators	Red LED for error Green LED for run Yellow LED for traffic
Connector	2 RJ45 connectors on TP853
Current Consumption from CEX-Bus 24 V d.c.	Typical 150 mA
Power Dissipation	3.6 W typical
Weight	700 g (1.5 lb) (package CI855K01)
Dimensions	W 59 x H 185 x D 127.5 mm (W 2.3 x H 7.3 x D 5.0 inches)
Protective Rating	IP20 according to EN60529, IEC 529.
Certification	UL508 and UL60079-15 Hazardous location Class 1 Zone 2
Hot swap	Supported



## S100 I/O Interface - CI856 and TP856

Table 12. S100 I/O Interface - CI856 and TP856

Item	Value
Type	S100 I/O Communication Interface
Bus Capacity (one segment)	Max 5 I/O racks with 20 I/O units each
Galvanic Isolation	No
Status Indicators	Red LED for error Green LED for run Yellow LED for access time-out
Connector	36 pin center line miniature ribbon connector, female on TP856, for bus extension cable TK575/TK580.
Current Consumption from CEX-Bus 24 V d.c.	Typical 120 mA
Power Dissipation	2.9 W typical
Weight	700 g (1.5 lb) (package CI856K01)
Dimensions	W 59 x H 185 x D 127.5 mm (W 2.3 x H 7.3 x D 5.0 inches)
Protective Rating	IP20 according to EN60529, IEC 529.
Certification	UL508 and UL60079-15 Hazardous location Class 1 Zone 2
Hot swap	Supported

## INSUM Interface - CI857 and TP853

Table 13. INSUM Interface - CI857 and TP853

Item	Value
Type	Ethernet unit Signal levels, IEEE802.3, 10 Base T
Protocol	TCP/IP
Communication speed	10Mbit/s (half duplex)
Status Indicators	Red LED for error Green LED for run Yellow LED for traffic
Connector	2 RJ45 connectors on TP853 (only one connector, COM1, can be used)
Current Consumption from CEX-Bus 24 V d.c.	Typical 150 mA
Power Dissipation	3.6 W typical
Weight	700 g (1.5 lb) (package CI857K01)
Dimensions	W 59 x H 185 x D 127.5 mm (W 2.3 x H 7.3 x D 5.0 inches)
Protective Rating	IP20 according to EN60529, IEC 529.
Certification	UL508 and UL60079-15 Hazardous location Class 1 Zone 2
Hot swap	Supported

## DriveBus Interface - CI858 and TP858



CI858 cannot be used in an AC 800M High Integrity controller.

*Table 14. DriveBus Interface - CI858 and TP858*

Item	Value
Communication speed	4 Mbit/s
Status indicators	Red LED for error Green LED for run Yellow LEDs for traffic
Connectors	Three optical connectors pairs. HP/Agilent Technologies Versatile Link Series (HFBR family) optical transmitter/receivers are used.
Current consumption (from CEX-Bus 24 V DC)	200 mA max.
External supply voltage	17 V minimum 25 V typical 30 V max
Protection Rating	IP20 according to EN60529, IEC 529.
Certification	UL508 and UL60079-15 Hazardous location Class 1 Zone 2
Hot swap	Supported

## FOUNDATION Fieldbus High Speed Ethernet Interface - CI860 and TP860



CI860 cannot be used in an AC 800M High Integrity controller.

*Table 15. FOUNDATION Fieldbus High Speed Ethernet Interface - CI860 and TP860*

Item	Value
Type	FOUNDATION Fieldbus High Speed Ethernet Signal levels, IEEE802.3, 10 Base T, 100 Base TX
Protocol	FF HSE
Communication speed	10 Mbit/s / 100 Mbit/s
Status Indicators	Red LED for error Green LED for run Yellow LEDs for traffic Yellow LED for primary Yellow LED for dual mode
Connector	1 RJ45 connectors on TP860
Current Consumption from CEX-Bus 24 V d.c.	Typical 100 mA
Power Dissipation	2.4 W typical
Weight	455 g (1.0 lb) (package CI860K01)
Dimensions	W 59 x H 185 x D 127.5 mm (W 2.3 x H 7.3 x D 5.0 inches)
Protective Rating	IP20 according to EN60529, IEC 529.
Certification	UL508 and UL60079-15 Hazardous location Class 1 Zone 2
Hot swap	Supported

## TRIO/Genius Interface CI862



CI862 cannot be used in an AC 800M High Integrity controller.

Table 16. Genius/TRIO Interface CI862

Item	Value
Bus Type	Daisy-chained bus cable; single twisted pair plus shield or Twinax.
Protocol	similar to the RS422 standard
Communication speed	153.6 ext, 38.4, 76.8, 153.6 std kbit/s
Bus Capacity	(one segment) Max 32 devices. 16 devices at 38.4 Kbaud. Includes CI862 and Hand-held Monitor.
Bus Termination	75, 100, 120, or 150 ohm resistor at both ends of electrical bus cable.
Maximum Bus Length	2500 m (7500 feet) at 38.4 Kbaud, 1500 m (4500 feet) at 76.8 Kbaud, 1200 m (3500 feet) at 153.6 Kbaud extended, 700 m (2000 feet) at 153.6 Kbaud, standard. Maximum length at each baud rate also depends on cable type.
Galvanic Isolation	Yes
Status Indicators	Red LED for error Green LED for run Yellow LED for traffic Yellow LED for primary Yellow LED for dual mode
Connector	one 4 pin Phoenix style (connects TRIO FIELD BUS) one DB9S (male) (connects Hand-held Monitor) one DB9, female (connects CEX expansion bus)
Current Consumption from CEX-Bus 24 V d.c.	<i>Typical 190 mA (max. 200 mA)</i>
Dimensions	W 58 x H 165 x D 122 mm (W 2.3 x H 6.4x D 4.81 inches)
Hot swap	Supported

## Satt I/O Interface CI865



CI865 cannot be used in an AC 800M High Integrity controller.

*Table 17. Satt I/O CI865 Interface Specifications*

Item	Value
Type	Satt I/O Communication Interface
Galvanic isolation	Yes
Status indicators	Run normally green, FAIL exceptionally red, COM A/COM B
Connector	BNC
Current consumption (from CEX-Bus 24 V DC)	120 mA typical (200 mA max.)
Power dissipation	2.9 W typical
Capacity	Up to 3968 binary I/O channels
Protection Rating	IP20 according to EN60529, IEC 529
Weight	700 g (1.5 lb) (package CI856K01 with CI856 and TP856)
Dimensions	W 59 x H 185 x D 127.5 mm (W 2.9 x H 7.3 x D 5.0 in)
Certification	UL listing pending
Hot swap	Supported

## Modbus TCP Interface CI867

Table 18. Modbus TCP Interface CI867 - Technical Specification

Item	Value
Type	Ethernet unit
Galvanic isolation	Modbus TCP
Communication speed Ch1	10 Mbit/s / 100 Mbit/s defined in IEEE 802.3u 10/100Base-Tx
Communication speed Ch2	10 Mbit/s defined in IEEE 802.3 10Base-T
Status indicators	Running normally: Green. Exceptional fault: Red. Two traffic indicators – RxTx1 and RxTx2 -- controlled by traffic pace: Flashing Yellow Running as primary: Yellow. Running in a redundant configuration: Yellow.
Connectors	RJ45
Current consumption (from CEX-Bus 24VDC)	160 mA typical (250 mA max)
Power dissipation	3.8W typical
Protection Rating	IP20 according to EN60529, IEC 529.
Weight	700 g (1.5 lb) (package CI867K01with CI867 and TP867).
Dimensions	W 59 x H 185 x D 127.5 mm (W 2.9 x H 7.3 x D 5.0 in)
Certification	UL508 and UL60079-15 listings pending Hazardous location Class 1 Zone 2
Hot swap	Yes

## IEC 61850 Interface CI868

Table 19. IEC 61850 Interface CI868 - Technical Specification

Item	Value
Type	Ethernet unit
Protocol	IEC 61850
Communication speed CH1	10 Mbit/s / 100 Mbit/s defined in IEEE 802.3u 10/100Base-Tx
Status indicators	Running normally: Green. Exceptional fault: Red. Two traffic indicators – RxTx1 and RxTx2(LED will always be switched off) -- controlled by traffic pace: Flashing Yellow Running as primary: Yellow. Running in a redundant configuration: Yellow.
Connectors	RJ45
Current consumption (from CEX-Bus 24VDC)	160 mA typical (250 mA max)
Power dissipation	3.8W typical (6W max)
Protection Rating	IP20 according to EN60529, IEC 529.
Weight	500 g (700g with package) (package CI868K01with CI868 and TP867).
Dimensions	W 59 x H 185 x D 127.5 mm (W 2.9 x H 7.3 x D 5.0 in)



## AF 100 Interface CI869

Table 20. AF 100 Interface CI869 - Technical Specification

Item	Value
Type	Ethernet unit
Protocol	Advant Fieldbus 100
Communication speed TWP	1.5 Mbit/s
Status indicators	Running normally: Green. Exceptional fault: Red. One traffic indicator – Rx - controlled by traffic pace: Flashing Yellow Running as primary: Yellow. Running in a redundant configuration: Yellow.
Connectors	Twisted Pair (TWP)
Current consumption (from CEX-Bus 24VDC)	160 mA typical (250 mA max)
Power dissipation	3.8W typical (6W max)
Protection Rating	IP20 according to EN60529, IEC 529.
Weight	500 g.
Dimensions	W 59 x H 185 x D 127.5 mm (W 2.9 x H 7.3 x D 5.0 in)

## PROFINET IO Interface CI871

Table 21. PROFINET IO Interface CI871 - Technical Specification

Item	Value
Type	Ethernet unit
Protocol	PROFINET IO
Communication speed CH1	10 Mbit/s / 100 Mbit/s defined in IEEE 802.3u 10/100Base-Tx
Status indicators	Running normally: Green. Exceptional fault: Red. Two traffic indicators – RxTx1 and RxTx2(LED will always be switched off) -- controlled by traffic pace: Flashing Yellow Running as primary: Yellow. Running in a redundant configuration: Yellow.
Connectors	RJ45
Current consumption (from CEX-Bus 24VDC)	160 mA typical (250 mA max)
Power dissipation	3.8W typical (6W max)
Protection Rating	IP20 according to EN60529, IEC 529.
Weight	500 g (700g with package) (package CI871K01with CI871 and TP867).
Dimensions	W 59 x H 185 x D 127.5 mm (W 2.9 x H 7.3 x D 5.0 in)

## EtherNet/IP Interface CI873

Table 22. EtherNet/IP Interface CI873 - Technical Specification

Item	Value
Type	Ethernet unit
Protocol	EtherNet/IP
Communication speed CH1	10 Mbit/s / 100 Mbit/s defined in IEEE 802.3u 10/100Base-Tx
Status indicators	Running normally: Green. Exceptional fault: Red. Two traffic indicators – RxTx1 and RxTx2(LED will always be switched off) -- controlled by traffic pace: Flashing Yellow Running as primary: Yellow. Running in a redundant configuration: Yellow.
Connectors	RJ45
Current consumption (from CEX-Bus 24VDC)	160 mA typical (250 mA max)
Power dissipation	3.8W typical (6W max)
Protection Rating	IP20 according to EN60529, IEC 529.
Weight	500 g (700g with package) (package CI873K01 with CI873 and TP867).
Dimensions	W 59 x H 185 x D 127.5 mm (W 2.9 x H 7.3 x D 5.0 in)

## External Battery Back-up Unit - SB821

Table 23. External Battery Back-up Unit - SB821

<b>Item</b>	<b>Description</b>
Battery	Lithium battery, 3.6V 16 Ah
Dimensions	W 85.6 x H 136 x D 51 mm (W 3.4 x H 5.4 x D 2.0 inches)
Weight	600 g (1.3 lb) incl. TK821V020
Protective rating	IP20 according to EN60529, IEC 529
Certification	UL508

## External Rechargeable Battery Back-up Unit - SB822

Table 24. External Battery Back-up Unit - SB822

Item	Value
Battery	Rechargeable Lithium--Ion battery, 3.75V 2.3 Ah
Dimensions	W 85.6 x D 51 x H 136 mm (3.4 x 2 x 4.4 in)
Weight	600 g (1.3 lb) (package with SB822,battery and TK821V020)
Size	ANSI size D IEC size R20
Lithium content	0.8g ( )
Protection Rating	IP20 according to EN60529
Certification	UL508

## Power Supply Components

### SD831, SD832, SD833, SD834

Table 25. SD83x - Technical Data

Parameter	SD831 Converter	SD832 Converter	SD833 Converter	SD834 Converter
Rated output current (A)	3 A	5 A	10 A	20 A
Rated power output	72 W	120 W	240 W	480 W
Rated output voltage	d.c. 24 V	d.c. 24 V	d.c. 24 V	d.c. 24 V
Rated input power a.c. 120/230 V	134/143 VA 82/80 W	240/283 VA 134/133 W	447/514 VA 264/262 W	547/568 VA 519/511 W
Mains/input voltage, nominal. a.c. 47-63Hz	a.c. 100-240 V d.c. 110-300 V	a.c. 100-120 V a.c. 200-240 V Auto-select input	a.c. 100-120 V a.c. 200-240 V Auto-select input	a.c. 100-240 V d.c. 110-300 V
Mains voltage variation allowed	a.c. 90-264 V d.c. 88-375 V	a.c. 90-132 V a.c. 180-264 V	a.c. 90-132 V a.c. 180-264 V	a.c. 85-276 V d.c. 88-375 V
Max input voltage <0.5s	a.c. 264-300 V	a.c. 264-300 V	a.c. 264-300 V	a.c. 276-300 V
Primary peak current at power on at a.c.120/230V	<28/<54 A	<10 A	<10 A	<13 A
Power Factor (at rated output power) a.c. 120/230V typ	0.61/0.56	0.56/0.47	0.59/0.51	0.95/0.90
Heat dissipation a.c. 120/230 V	10/8 W	14/13 W	24/22 W	39.6/31.4 W
Efficiency factor a.c. 120/230 V typ	88/89.8%	89.4/90.2%	91/91.6%	92.4/93.9%
Line/load regulation	< 50 mV /< 100 mV	< 70 mV /< 100 mV	< 70 mV /< 100 mV	< 10mV /< 100mV
Ripple (peak to peak)	< 50 mV	< 50 mV	< 50 mV	< 100mV

Table 25. SD83x - Technical Data (Continued)

Parameter	SD831 Converter	SD832 Converter	SD833 Converter	SD834 Converter
Holdup time at mains blackout a.c. 120/230 V typ	29/120 ms	80/78 ms	46/47 ms	32/51 ms
Maximum output current	3.3 A	6 A At ambient temp < 45 °C	12 A At ambient temp < 45 °C	30 A < 4 s
Maximum ambient temperature <sup>(1)</sup>	55 °C	55 °C	55 °C	55 °C
Acceptable wire sizes Power connection terminals	Solid: 0.5 – 6 mm <sup>2</sup> Stranded wire: 0.5 – 4 mm <sup>2</sup> , 20 – 10 AWG Recommended torque: 0.8 Nm			
Acceptable wire sizes DC-OK-signal terminals				Solid: 0.3 - 4 mm <sup>2</sup> Stranded wire: 0.3 - 2.5 mm <sup>2</sup> , 26 - 12 AWG

(1) Mounting on a horizontal DIN rail.

## SS822, SS823

Table 26. SS82x - Technical Data

Parameter	SS823 Voter
Rated Output Current (A)	20 A
Rated Output Power	-
Rated Output Voltage	24 V
Rated Input Power (at full load)	500 W
Efficiency Factor	-

Table 26. SS82x - Technical Data (Continued)

Parameter	SS823 Voter
Mains/Input Voltage, (nominal)	1 x 24 V d.c.
Mains Voltage Variation	-
Primary Peak Current at Power On	-
Heat Dissipation	24 W
Secondary Voltage Holdup Time at Mains Blackout	-
Dimensions, Width HxD = 125 x 110mm (4.9 x 4.3 inches)	140 mm (5.5")
Mounting Spacing W mm (along DIN rail)	15 mm (0.6")
Mounting Spacing H mm (above each other)	30 mm (1.2")
Weight (lb)	870 g (1.9 lb)
Protective Rating	IP20 according to EN60529, IEC 529
Certification	UL508



## SS832

Table 27. SS832 - Technical Data

Parameter	SS832 Voter
Input current	10A per input
Rated output current	20 A
Mains/input voltage, nominal	2 x 24 V d.c.
Rated/input voltage	60 V d.c.
Heat dissipation	8.9 W at 10 A and 4.6 W at 5 A
Input to output voltage drop at max. current	0,85 V
Maximum output current	25 A (Overload)
Ingress Protection	IP20 according to EN60529, IEC 60529.
Max ambient temperature	55°C <sup>(1)</sup>
Acceptable wire sizes	Solid: 0.5 - 6 mm <sup>2</sup> , 20 - 10 AWG Stranded: 0.5 - 4 mm <sup>2</sup> , 20 - 10 AWG Recommended torque: 0.8 Nm
Dimensions	
Width	32 mm (1.26")
Depth	117 mm (4.6")
Height	124 mm (4.9")
Mounting spacing W	5 mm (0.2"), In case the adjacent device is a heat source 15 mm (0.59")
Mounting spacing H	40 mm (1.57") on the top, 20 mm (0.79") on the bottom
Weight	350 g (0.77 lbs.)

(1) Mounting on a horizontal DIN rail

# DIN Rail and Al-profile

Table 28. DIN Rail and Al-profile - Required Dimensions

Cabinet / Application	Al-Profile (length)	DIN rail (length)
For RE820 Cabinet	719 mm (28.3")	683 mm (26.9")
For RM550 Cabinet	592 mm (24")	556 mm (21.9")
For Standard Use	465 mm (19")	429 mm (16.9")

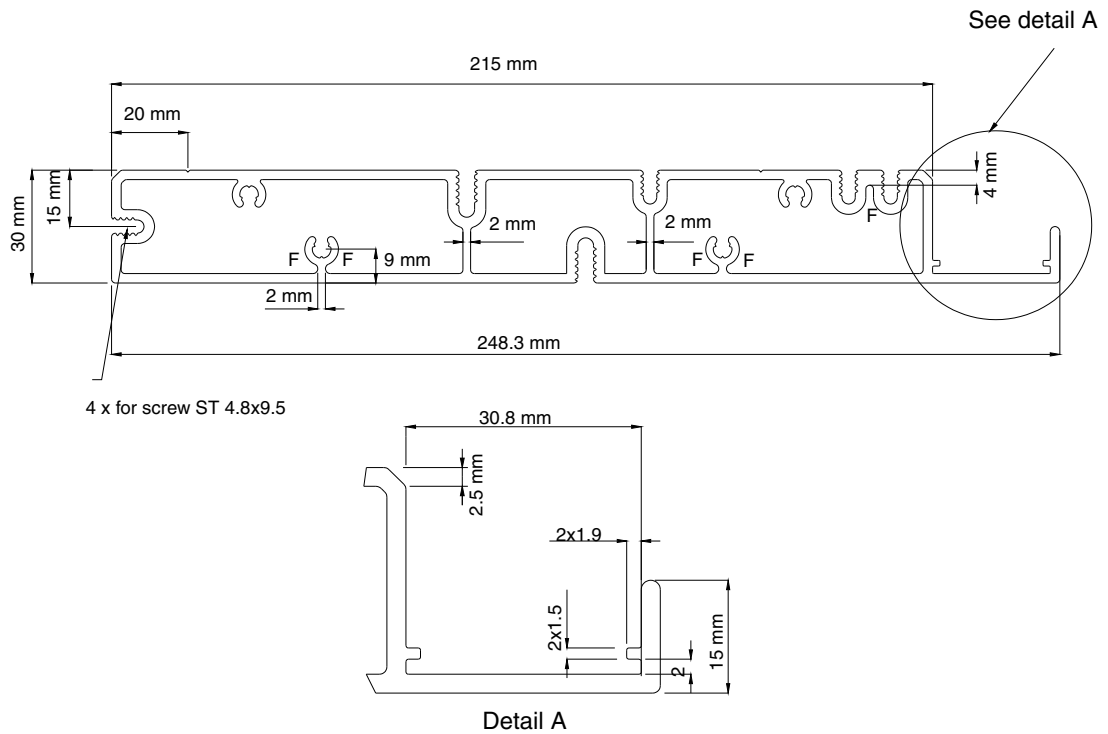

Figure 54. Al-Profile for DIN-rail - Dimension Drawing

---

## Section 7 Ordering

### Ordering Procedure

The product guide is aimed to assist ABB sales representatives in ordering AC 800M Hardware products.

This section describes the price lists required when ordering and provides an example of an order. However, it is outside the scope of this product guide to give a complete description of all ordering procedures and tools. It is assumed that each ABB sales representative is familiar with price lists, CAST and other tools to order.

### Price List Structure

For information on the price list for AC 800M, version 5.1 and later, see the System Guide, Ordering and Licensing (3BSE041435\*) (see [Released User Manuals and Release Notes](#) on page 16).

The AC 800M price list contains all the AC 800M units (processor, communication units and power supplies) that can be ordered.



---

# Appendix A Power Consumption

## General

At an ambient temperature of 40°C (104°F) it is considered unnecessary to calculate the heat dissipation requirements for a standard AC 800M Controller with S800 I/O configuration, mounted within ABB floor-mounted or wall-mounted cabinets.

For a standard AC 800M Controller configuration housed within a floor-mounted or wall-mounted cabinet, the recommended fuse rating for the external mains supply is:

*Table 29. AC 800M Mounted in ABB Cabinet – Fuse Requirements*

Fuse Rating	Fuse Type
10 A	Delayed-action fuse

Should the configuration be other than that stated, detailed instructions for calculating current consumptions can be found in the following text.

The following tables present current consumption and power dissipation for all relevant hardware units included in AC 800M Controller.

Use this information:

- dimensioning the supply requirements of an AC 800M and S800 I/O configuration.
- calculating cabinet-generated power loss.

The values given in the tables are typical and adapted to these applications. It is assumed that 70% of unit channels are active simultaneously.

## Current Consumption and Power Dissipation

See [Table 30](#) on page 158 for typical current consumption and power dissipation data for AC 800M units.

*Table 30. Current Consumption and Power Dissipation Data for AC 800M Units*

Unit	Current at 24 V		Power Dissipation		Remarks
	Typical	Max	Typical	Max	
PM851/ PM851A	180 mA	300 mA	5.0 W	8.0 W	(1)
PM856/ PM856A	180 mA	300 mA	5.0 W	8.0 W	(1)
PM860/ PM860A	180 mA	300 mA	5.0 W	8.0 W	(1)
PM861/861A	250 mA	430 mA	6.0 W	10.3 W	(1)
PM864/864A	287 mA	487 mA	6.9 W	11.4 W	(1)
PM865	287 mA	487 mA	6.9 W	11.4 W	(1)
PM866	210 mA	360 mA	5.1 W	8.6 W	(1)
PM891	660 mA	750 mA	15.8 W	18 W	(1)
BC810	50 mA	70 mA	1.2 W	1.7 W	
SM810	160 mA	250 mA	3.8 W	6.0 W	
SM811	160 mA	250 mA	3.8 W	6.0 W	
CI851	150 mA	200 mA	3.6 W	4.8 W	
CI852	140 mA	200 mA	3.4 W	4.8 W	
CI853	100 mA	150 mA	2.4 W	3.6 W	
CI854/854A	190 mA	240 mA	4.6 W	5.8 W	
CI855	150 mA	200 mA	3.6 W	4.8 W	
CI856	120 mA	200 mA	2.9 W	4.8 W	
CI857	150 mA	200 mA	3.6 W	4.8 W	
CI858	150 mA	200 mA	3.6 W	4.8 W	

Table 30. Current Consumption and Power Dissipation Data for AC 800M Units

Unit	Current at 24 V		Power Dissipation		Remarks
	Typical	Max	Typical	Max	
CI860	100 mA	150 mA	2.4 W	3.6 W	
CI862	190 mA	200 mA	4.6 W	4.8 W	
CI865	120 mA	200 mA	2.9 W	4.8 W	
CI867	160 mA	250 mA	3.8 W	6.0 W	
CI868	160 mA	250 mA	3.8 W	6.0 W	

- (1) These figures apply only to the PM8xx. For current-consumption data relating to the CEX-Bus and the ModuleBus units, see [Table 31](#) on page 159. Due to transfer or conversion losses in the CPU when current supply to ModuleBus and CEX-Bus is utilized, the CPU power dissipation increases by maximum 5 W (3 W for PM851/PM851A) in addition to the values given in [Table 30](#) on page 158.

The CPU supplies current, via TP830, to units on the CEX-Bus and ModuleBus, see [Table 31](#) on page 159.

Table 31. CPU Current Supply to CEX-Bus and ModuleBus

Bus	+5 V	+24 V
ModuleBus	max. 1.5 A <sup>(1)</sup>	max. 1.0 A
CEX-Bus	Not Applicable	max. 2.4 A

- (1) Corresponds to additional 0.5 A on +24 V.

Maximum current of the +24 V supplied to the CPU (incl. ModuleBus and CEX-Bus) is shown in [Table 32](#) on page 159:

Table 32. Maximum Current Supply to CPU incl. ModuleBus and CEX-Bus (24 V)

CPU	Maximum Supply Current
PM851/PM851A	2.2 A
PM856/PM856A	4.2 A
PM860/PM860A	4.2 A

Table 32. Maximum Current Supply to CPU incl. ModuleBus and CEX-Bus (24 V)

CPU	Maximum Supply Current
PM861/861A (single)	4.3 A
PM861/861A (redundant pair)	3.3 A (no ModuleBus)
PM864/864A (single)	4.4 A
PM864/864A (redundant pair)	3.4 A (no ModuleBus)
PM865 (single)	4.4 A
PM865 (redundant pair)	3.4 A (no ModuleBus)
PM866 (single)	4.2 A
PM866 (redundant pair)	3.2 A (no ModuleBus)
PM891(single)	3.2 A (no ModuleBus)
PM891 (redundant pair)	3.9 A (no ModuleBus)

## Calculations

1. Calculate the current requirements for each bus (ModuleBus and CEX-Bus). Be sure not to exceed the limits given in [Table 31](#) on page 159. Data relating to TB820, TB840 and CI830 is accessible from the S800 I/O documentation.
2. Calculate the current consumption at 24 V, for each electrical ModuleBus, by adding:

$$I_m = I_{(24\text{ V})} + I_{(5\text{ V})} \times 0.3$$

3. To calculate the requirement for a specific power supply unit, total the results of the 24V current consumption calculations, as follows:

$$I_{\text{tot}} = I_{m1} + I_{m2} + \dots + I_{\text{units Table 30}} + I_{\text{CI830s}} + I_{\text{TB820s}} + I_{\text{TB840s}}$$

If redundant CPUs are used, current for both CPUs must be included.



---

# Appendix B Recommended Components

## Recommended Components

All recommended components listed below were successfully utilized during exhaustive tests made by ABB, prior to launching the AC 800M Controller.

Table 33. Recommended Components – PROFIBUS DP

<b>Component</b>	<b>Description</b>
PROFIBUS DP	<p>Due to the large selection of commercially available equipment manufactured to PROFIBUS DP Standard, there is no recommendation for specific PROFIBUS DP components.</p> <p>For further details refer to PROFIBUS DP Web Site.</p>
PROFIBUS DP/PA Linking Device (LD 800P)	<p>LD 800P performs the following tasks:</p> <ul style="list-style-type: none"> <li>• Potential separation between the PROFIBUS DP and the PROFIBUS PA</li> <li>• Conversion of the RS 485 physical arrangement of the PROFIBUS DP to the physical arrangement based on IEC 61158-2 of the PROFIBUS PA.</li> <li>• Adapting the PROFIBUS DP transfer rate to the PROFIBUS PA transfer rate of 31.25 kBd.</li> <li>• Power supply of PROFIBUS PA stations over the bus line.</li> <li>• Diagnostics via LEDs.</li> <li>• Ensuring intrinsic safety if the PL 890 power link module with an intrinsically safe interface is used.</li> </ul> <p>A PROFIBUS DP master (class 1 master), which organizes the exchange of process data, is contained in the controller (PLC/PCS). Moreover, a configuration tool, usually a PC, can be connected as class 2 master to the PROFIBUS DP. Parameterization and configuration of the bus elements usually takes place by means of this configuration tool - even during operation. This is performed using the acyclic channel of the PROFIBUS DP or PROFIBUS PA. LD 800P supports both cyclic as well as acyclic PROFIBUS communication.</p>

Table 33. Recommended Components – PROFIBUS DP (Continued)

Component	Description
PROFIBUS DP/PA Linking Device (LD 800P) (cont.)	<p>The way in which LD 800P works is essentially transparent. This means that PROFIBUS DP masters have direct access to PROFIBUS PA slaves. This offers the following advantages:</p> <ul style="list-style-type: none"><li>• No configuration of the Linking Device is required</li><li>• PROFIBUS PA slaves can be treated like PROFIBUS DP slaves</li><li>• There is no PROFIBUS DP address setting on the Linking Device</li><li>• Because of this, there is no restriction on the amount of data to 244 bytes of I/O data per PROFIBUS PA segment for the PROFIBUS PA.</li></ul> <p>See <a href="#">Figure 55</a> on page 164 for LD 800P Interface. For more information see fieldbus documentation.</p>

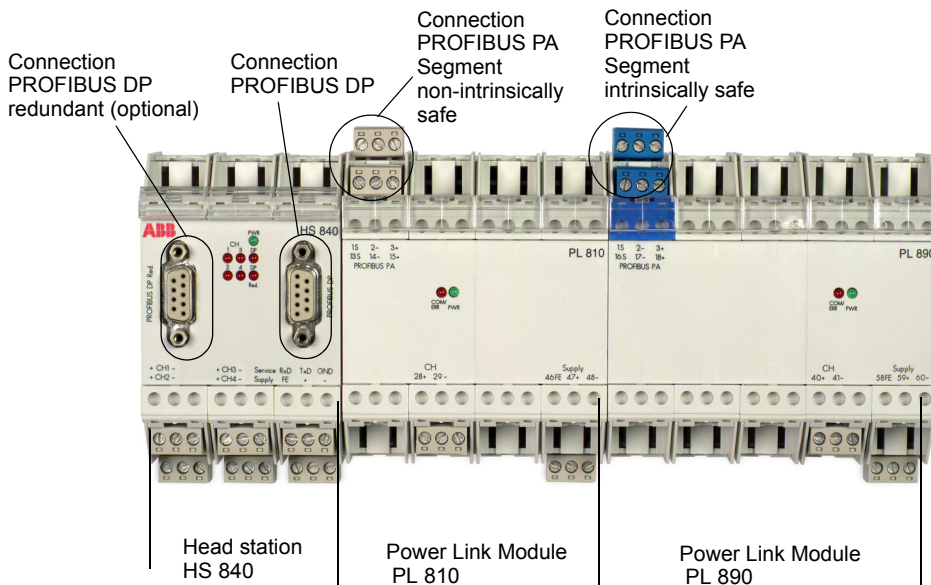

Figure 55. LD 800P Interface

Table 34. Recommended components - PROFINET IO

Component	Description
MNS <i>iS</i>	MNS <i>iS</i> is a motor control center solution that can be used in PROFINET IO network. MNS <i>iS</i> delivers all the functions for control, protection and monitoring of motors and motor starters using software and hardware modules for the specific tasks. <i>MLink</i> , one of the interface modules in MNS <i>iS</i> , serves as the serial gateway interface to higher level systems which communicate to all modules through PROFINET IO.

*Table 35. Recommended components - EtherNet/IP and DeviceNet*

<b>Component</b>	<b>Description</b>
LD 800DN	The LD 800DN adapter, which functions as a gateway to connect control level networks with device level networks, provides a router or bridge functionality to connect EtherNet/IP to DeviceNet. The LD 800DN provides centralized data storage for data that is shared between the DeviceNet and Ethernet/IP networks.

Table 36. Recommended Components – FOUNDATION Fieldbus

<b>Component</b>	<b>Description</b>
FOUNDATION Fieldbus	<p>Due to the large selection of commercially available equipment manufactured to FOUNDATION Fieldbus Standard (IEC 1158-2), there is no recommendation for specific FOUNDATION Fieldbus components.</p> <p>This statement covers all FOUNDATION Fieldbus equipment, including:</p> <ul style="list-style-type: none"><li>• FOUNDATION Fieldbus filters.</li><li>• FOUNDATION Fieldbus bus spur distribution terminals.</li><li>• FOUNDATION Fieldbus termination.</li></ul> <p>For further details refer to FOUNDATION Fieldbus documentation and the FOUNDATION Fieldbus Web Site.</p>

Table 37. Recommended Components – FOUNDATION Fieldbus High Speed Ethernet

Component	Description
FOUNDATION Fieldbus High Speed Ethernet	<p>All used components must be compatible with the FOUNDATION Fieldbus High Speed Ethernet specification.</p> <p>FOUNDATION Fieldbus High Speed Ethernet use a high speed bus (for example 100 Mbit/s) and in addition providing redundancy. The HSE architecture is effectively an enhanced standard Ethernet model (IEEE 802.3). The HSE Application Layer contains the Dynamic Host Configuration Protocol (DHCP), Simple Network Time Protocol (SNTP) and Simple Network Management Protocol (SNMP).</p> <p><b>System data High Speed Ethernet (HSE)</b></p> <p><b>Max. devices:</b> Has IP addressing, which can support unlimited nodes</p> <p><b>Max. baudrate:</b> 100 Mbit/s</p> <p><b>Typical max. extension:</b> 100m at 100Mbit/s on twisted pair, 2000m at 100Mbit/s on fibre</p> <p><b>Vendor specific restrictions apply.</b></p> <p><b>Physical Media:</b> Twisted pair, fibre</p> <p><b>Network Topology:</b> Star</p>

Table 37. Recommended Components – FOUNDATION Fieldbus High Speed Ethernet (Continued)

Component	Description
FOUNDATION Fieldbus Linking Device (LD 800HSE)	<p>The LD 800HSE is a gateway between an FF High Speed Ethernet (FF-HSE) subnet and FF-H1 links. It supports device redundancy.</p> <p>The Linking Device is designed according to class 42c of the HSE profile, therefore providing the following functions:</p> <ul style="list-style-type: none"> <li>• It supports up to four separate FF-H1 links. In each of these links, the Linking Device can be operated as the Link Master as well as the Time Manager.</li> <li>• Identification of the devices connected to the H1 links.</li> <li>• Configuration of the connected H1 devices by <b>System Management</b> and <b>Network Management</b> via HSE.</li> <li>• Access to the function blocks of the connected H1 devices via HSE.</li> <li>• <b>Republishing</b> of process data from one H1 link into another.</li> <li>• <b>Republishing</b> of process data from H1 to HSE and vice versa.</li> </ul> <p>See <a href="#">Figure 56</a> on page 169 for LD 800HSE Interface. For more information see fieldbus documentation.</p>



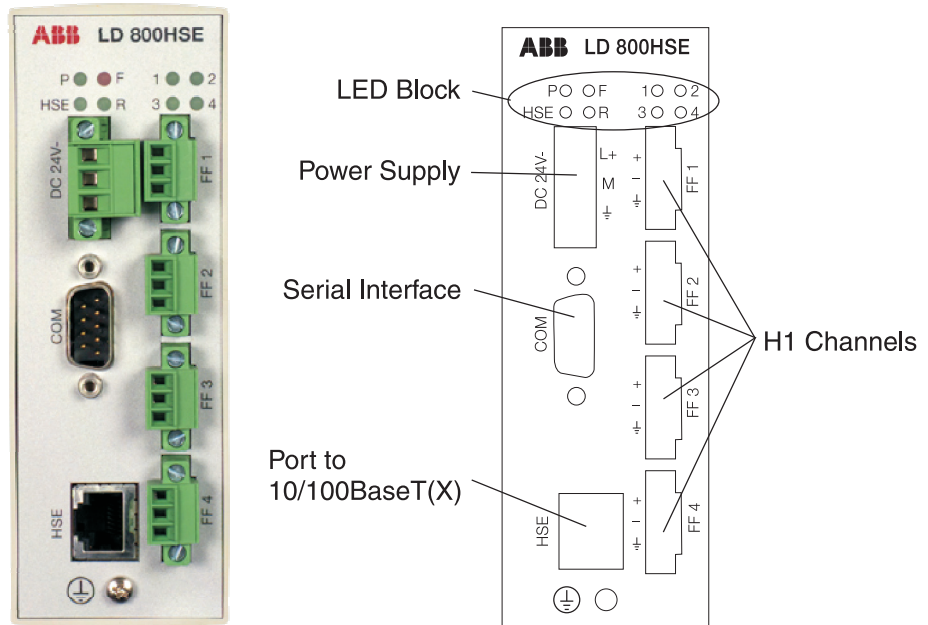

Figure 56. LD 800HSE Interface

Table 38. Recommended Components for Control Networks

Component	Description
HUBS (For Non-Industrial Environments)	3Com Hub, 8/TPO – (8 ports, RJ45) BayStack, 350/24 – (24 port, Star topology, RJ45)
HUBS (Industrial Environments)	Hirschmann Rail Hub RH1-TP– (4 ports, RJ45)
SWITCHES (Industrial Environments)	Hirschmann Rail Switch RS2 (8 ports, Ring, Bus or Star topology RJ45) On-Time Switch (FSU100 series, FSU200 series, FSU208, FSR208, FST208)
CABLES	Electrical – Class 5, or higher, STP Optical – As recommended by Manufacturer of HUBS and SWITCHES

Table 39. Recommended Components – Miscellaneous

Component	Description
DIN-rail	Phoenix: <ul style="list-style-type: none"> <li>• TS 35/7.5</li> <li>• Steel, yellow chromated with holes</li> <li>• DIN 46 277, EN 50 022</li> </ul>
DIN-rail Accessories	DIN-rail end support device Phoenix: UK 4-TG+ST-BE (Standard commercially available components)
Cabinets	ABB Automation Technology Products, LV systems Wall cabinet RE820 <ul style="list-style-type: none"> <li>• for 3 DIN-rails</li> <li>• W 800 x H 1200 x D 330 mm (31.5 x 40.1 x 13.0 in)</li> <li>• IP54</li> </ul> Floor cabinet RM550 <ul style="list-style-type: none"> <li>• for 6 DIN-rails</li> <li>• W 840 x H 2125 x D 512 mm (33.1 x 83.7 x 20.2 in)</li> <li>• IP54</li> </ul> See <a href="#">Figure 49</a> on page 114, <a href="#">Figure 50</a> on page 115 and <a href="#">Figure 51</a> on page 116.

Table 40. Recommended Components – Process Cables

Component	Description
Mains	Various Manufacturers, to Standard; <ul style="list-style-type: none"> <li>• RKFk 3x1.5 mm<sup>2</sup></li> </ul>
RS-232C	Unitronic <ul style="list-style-type: none"> <li>• CY 3 x 0.25 mm<sup>2</sup></li> <li>• CY 7x 0.25 mm<sup>2</sup></li> </ul> Belden <ul style="list-style-type: none"> <li>• Belden 8723 2 pair (0.34 mm<sup>2</sup>)</li> <li>• Belden 9729 2 pair (0.22 mm<sup>2</sup>)</li> <li>• Belden 9730 3 pair (0.34 mm<sup>2</sup>)</li> </ul>
FOUNDATION Fieldbus	Unitronic <ul style="list-style-type: none"> <li>• Suitable Commercially Available Cable.</li> </ul> Belden <ul style="list-style-type: none"> <li>• Suitable Commercially Available Cable.</li> </ul>
FOUNDATION Fieldbus High Speed Ethernet	<ul style="list-style-type: none"> <li>• All cables must correspond to ISO / IEC 11801 2nd edition. Use in minimum cable of category 5 / link class D (UTP cables).</li> <li>• max. length 100 m from CI860 to next Ethernet device (Twisted pair).</li> </ul>
PROFIBUS DP	Unitronic <ul style="list-style-type: none"> <li>• Twisted pair, 0.34 mm<sup>2</sup></li> <li>• Unitronic-Bus L2/F.I.P</li> </ul> Belden <ul style="list-style-type: none"> <li>• Twisted pair, 0.34 mm<sup>2</sup></li> <li>• Belden 3079A</li> </ul>

Table 40. Recommended Components – Process Cables

Component	Description
Modbus TCP Interface CI867	<ul style="list-style-type: none"> <li>• Use in minimum cable of category 5 (STP cables)</li> <li>• Max. length 30 m from CI867 to next Ethernet device.</li> </ul>
IEC 61850 Interface CI868	<ul style="list-style-type: none"> <li>• Use in minimum cable of category 5 (STP cables)</li> <li>• Max. length 30 m from CI868 to next Ethernet device.</li> </ul>
AF 100 Interface CI869	<ul style="list-style-type: none"> <li>• Twisted pair cable according to IEC 1158-2 fieldbus standard.</li> <li>• Max. 750m per segment.</li> </ul>
EtherNet/IP Interface CI873	<ul style="list-style-type: none"> <li>• Use in minimum cable of category 5 (STP cables).</li> <li>• Max. length 30 m from CI873 to next Ethernet device.</li> </ul>



---

# Appendix C Directive Considerations

Relevant products comply with EMC Directive EMCD 2004/108/EC and Low Voltage Directive LVD 2006/95/EC. The products are provided with a CE marking.

## Electro-Magnetic Compatibility (EMC)

Modules mentioned in this document, for which the product or packing is CE marked, are tested and approved according to the following standards:

- EN 61131-2 Product Standard, Programmable Controller  
- Industrial Environment
- EN 61000-6-4 EMC – Generic Emission Standard,  
Part 4 – Industrial Environment
- EN 61000-6-2 EMC – Generic Immunity Standard,  
Part 2 – Industrial Environment.

## Low-Voltage Directive (LVD)

Modules mentioned in this manual, for which product or packing is CE marked, comply with the LVD where applicable.

To fulfill the LVD for AC 800M and S800 I/O, the power supplies shall provide a secondary safety extra low voltage (SELV) or a protected extra low voltage (PELV). The power supplies described in this manual, fulfill these requirements, see [Power Supply Components - SD83x and SS832](#) on page 102 and [Power Supply Units - SD831, SD832, SD833, and SD834](#) on page 102.



If you use other power supplies, except SD82X and SD83X, to provide the 24V d.c. for AC 800M it is required that they also are CE marked, UL listed and fulfill the LVD (SELV and PELV).



The AC 800M modules are to be considered as open equipment, according to EN 61131-2 and UL508, and must be mounted in non-public localities.



---

## Appendix D Standards

The information below is applicable to products approved for hazardous locations according to CSA and/or UL standard UL60079-15 (2002).

### Hazardous Location Approval

To comply with CSA and/or UL certification for use at hazardous locations, the following information is relevant for CSA and/or UL-certified ABB industrial control products.

- Equipment labeled with reference to Class I, Zone 2, AEx nC IIC, hazardous locations is suitable for use in Class I, Zone 2, AEx nC IIC, or non-hazardous locations only.
- Equipment labeled with reference to Class I, Zone 2, AEx nC IIC, hazardous locations and is to be mounted in Class I, Zone 2, AEx nC IIC, hazardous locations requires an overall enclosure or cabinet with ingress protection rating of IP54 as a minimum. The enclosure shall be capable to withstand an impact of minimum 7 joule and installation is only allowed in pollution degree 2 environment or lower.
- Equipment labeled with reference to Class I, Zone 2, AEx nC IIC, hazardous locations and is to be mounted in Class I, Zone 2, AEx nC IIC, hazardous locations requires that provisions are made to prevent transient disturbances of more than 40% of rated voltage.



Explosion hazard - Substitution of components may impair suitability for Class I, Zone 2.



Explosion hazard - Do not replace batteries unless the power has been switched off or the area is known to be non-hazardous.



Explosion hazard - Do not disconnect equipment unless the power has been switched off or the area is known to be non-hazardous.

---

# Appendix E Environmental Data

## Environmental Data for AC 800M Products

The immunity of products to environmental factors met during operation, transportation and storage is summarized in this section.

**Industrial environment** are supplied with power from a high-voltage or medium-voltage transformer dedicated to supplying installations feeding manufacturing or similar plants. The existence of industrial apparatus and heavy, frequently-switched inductive or capacitive loads characterize an **Industrial environment**. The associated magnetic fields are high.

Control products incl. I/O-systems are normally intended for **Industrial environment**.

Products manufactured by ABB and other companies are normally type-tested or evaluated to ensure compliance with the environmental standards specified below.

Environmental specifications applicable to peripheral equipment, for example printers, may differ. Please refer to the relevant product data sheets.

The degree to which the units resist environmental influence depends on their components and design. System enclosures, cable types and how these are routed determine the environmental specification of the entire system.

## Climatic and Mechanical Environmental Conditions

### Industrial Environment

Table 41. Industrial Environment

Environmental Specification				Compliance with Standard
	Environment Factor	Transportation and Storage	Operative Range	
<b>Climatic Conditions</b>	Temperature	-40 to +70°C  -40 to +60°C	<b>Cabinets</b> <sup>(1)</sup> : +5 to +40°C <b>Units</b> <sup>(2)</sup> : +5 to +55°C +10 to +40°C <sup>(3)</sup>	EN 61131-2
	Temp. change	Min. 3 min within temp. range	3°C/min.	EN 61131-2
	Humidity	RH=5-95% RH=20-80% <sup>(3)</sup> non-condensation	RH=5-95% RH=20-80% <sup>(3)</sup> max 29 g/m <sup>3</sup> non-condensation	EN 61131-2
	Altitude	3000 m	2000 m	EN 61131-2
	Pollution degree	Degree 2		IEC 60664
	Corrosion	Copper corrosion of 300 Angstrom <sup>(4)</sup> over 28 days	Copper corrosion of 300 Angstrom <sup>(4)</sup> over 28 days	ISA 71.04 class G1 ITF SSG 4251G1

Table 41. Industrial Environment (Continued)

Environmental Specification				Compliance with Standard
	Environment Factor	Transportation and Storage	Operative Range	
Mechanical Conditions	Vibration	10 < f < 50 Hz, Continuous: 0.0375 mm amplitude (Occasional: 0.075 mm amplitude) 50 < f < 150 Hz, Continuous: 0.5 g acceleration (Occasional: 1.0 g acceleration)		EN 61131-2
	Emitted noise	–	<55dB (A)	
	Shock, no package	5 > f < 8.4 Hz, Continuous: 1.75 mm displacement (Occasional 3.5 mm displacement). 8.4 > f < 150 Hz, Continuous 0.5 g acceleration (Occasional 1.0 g acceleration).		EN 61131-2
	Fall in package	<10 kg: 1 m 10–40 kg: 0.5 m >40 kg: 0.25 m >100 kg: 0.025 m		EN 61131-2

- (1) **Cabinets** = Enclosures, Cases, Consoles
- (2) **Units** = Subracks, plug-in units, printed circuit boards
- (3) **Workstation, PC computers and peripherals**, for example printers
- (4) 1000 Angstrom for S800 I/O-family

## CE Compliance

All products comply with EMC Directive EMCD 2004/108/EC and Low Voltage Directive LVD 2006/95/EC (relevant products also comply with the Teleterminal Directive). Products are CE-marked. Some products require enclosures, as specified in User Guides, to meet the EMC Directives.

Compliance is verified through conformity with the following minimum standards:

- EMC Directive EMCD 2004/108/EC.
- EN 61131-2 Product standard, Programmable controllers.
- EN 61000-6-4 Generic emission standard.
- EN 61000-6-2 Generic immunity standard.
- Low Voltage Directive LVD 2006/95/EC.

## Electromagnetic Compatibility and Main Voltage Conditions

Table 42. Electromagnetic Compatibility and Main Voltage Conditions

Environmental Specification			Compliance with Standard
	Environment Factor	Industrial Environment	
Electromagnetic Compatibility Conditions	Emission –Radiated –Conducted	Class A	EN 55011
	Immunity –Radiated RF field	10V/m 80M - 1000MHz 3V/m 1.4G - 2.0GHz 1V/m 2.0G - 2.7GHz	EN 61000-4-3
	Immunity –Conducted RF field	10 V	EN 61000-4-6
	Immunity –ESD (Electrical Discharge)	±4kV contact discharge ±8kV air discharge	EN 61000-4-2
	Immunity –EFT/B (Electrical Fast Transient/Burst)	±2kV power ports ±1kV other lines	EN 61000-4-4
	Immunity –Damped oscillatory wave	–	IEC 60255-22-1
	Immunity –Power frequency magnetic field	30 A/m, cont. 3 A/m for CRTs	EN 61000-4-8
	Immunity –Surge	±0.5kV common ±0.5kV differential	EN 61000-4-5

Table 42. Electromagnetic Compatibility and Main Voltage Conditions

Environmental Specification			Compliance with Standard
	Environment Factor	Industrial Environment	
Electromagnetic Compatibility Conditions	Main voltage a.c	$U_{nom}$ : -15% to +0%	
	Main voltage DC	-15% to 20% of rated value	
	Main frequency a.c.	47–63 Hz, $\pm 5\%$	IEC 60255-6
	Main voltage interruption, a.c.	Max 10 ms	EN 61000-4-11
	Overvoltage Category –Permanently connected equipment	Class III	
	Overvoltage Category –Non-permanently connected equipment	Class II	



## Installation Requirements

Installation regulations for all products are included in relevant product documentation. Some general installation rules and applications are given below.

### Laying Field Cables

There are no special requirements for laying field and communication cables connected to products. However:

Cables for short-distance communication without modems should always be routed at a distance of 10 cm (4 in.) from other cables.

All product-connected cables should be routed at a distance of 30 cm (12 in.) from non-product power cables (heavy current cables) and 10 cm (4 in.) from class 4 cables of relevant international immunity standards.

### Types of Field Cable

Shielded cables are always necessary for:

- Communications (see product documentation for cable type)
- High-frequency pulse transmission (see product documentation for cable type)
- Low-level analog signals, for example Pt100 and thermocouples

For other applications unshielded cables may be used. Digital and analog signals of the same type can be run on the same cable.

Signal and return conductors should be located on the same cable.

### DIN-rail mounting

It is required that the DIN-rail is properly attached to either the prefabricated aluminum profile or a metal sheet with conductive surface. The fulfilment of this requirement will ensure mechanical stability and enable a stable and well defined ground plane for the chassis, which is of great importance from EMC perspective.

## **Lightning Protection**

Industrial installations and power plants are normally provided with well-integrated grounding networks, installed as part of the power distribution system. Such installations do not require additional lightning protection.

Additional lightning protection is always necessary when:

- Cables extend beyond the area covered by the ground line network
- Cables are located above ground
- Overhead cables are used.

## **Inductive Load Suppression**

Inductive loads, such as relays and contactors connected directly to products, do not require suppression. The necessary suppression components (varistors or snubbers-RC units) are installed on the circuit boards.

---

# INDEX

## A

ABB Drives 31, 44  
AC 800M 36, 49, 51, 53, 86  
AF100 31  
AI-profile 106, 154  
Applicable Specifications 15

## B

Base plate 23  
Battery Back-up 32  
    External battery 99, 123, 148 to 149  
    External battery SB822 99  
    Internal battery 99, 122  
BC810 63, 130  
Branching Unit 46

## C

Cabinet Design 113  
CAST 155  
CEX-Bus 24, 26, 31, 55, 58, 86, 126  
    Extension 107  
    Termination 107  
CEX-Bus Interconnection Unit 130  
CI 860 86  
CI830 44  
CI840 36  
CI851 72, 133  
CI853 74, 134  
CI854 36, 76, 135  
CI854A 36, 76, 135  
CI855 78, 136  
CI856 36, 80, 137  
CI857 82, 138  
CI858 139  
CI860 86, 140

CI862 36, 38  
CI867 92, 143  
CI868 71, 93, 144  
CI869 94, 145  
CI871 96, 146  
CI873 98, 147  
CN1 53, 55, 58, 125  
CN2 53, 55, 58, 125  
COM3 56, 125  
COM4 56, 125  
Communication 31, 70, 125, 134  
Control Builder 53, 56  
Control Network 56, 58  
CPU 53, 55, 121  
Current consumption 158  
    PM851/PM851A/PM856/PM856A/PM860/P  
    M860A/861/864 127

## D

DIN rail 18, 32, 49, 106, 154  
DriveBus 84, 139  
DSBC173A 37  
DSBC174/DSBC176 37

## E

Electro-Magnetic Compatibility 175  
Ethernet ports 24, 26  
EUROPEAN UNION DIRECTIVE  
    COMPLIANCE 15  
External battery 32

## F

Fieldbus Builder FOUNDATION Fieldbus 86  
Fieldbus Communications Interface 37  
FOUNDATION Fieldbus High Speed Ethernet 31,

86, 140  
Fuse Requirement 157

## G

Grounding 34

## I

I/O-system 36  
I/O-systems 179  
INSUM 31, 82, 138  
internal battery 32

## L

Low-Voltage Directive 175

## M

MasterBus 300 31, 78, 136  
Modbus TCP/IP Interface 92  
ModuleBus 23 to 24, 36, 44, 55, 58, 125 to 126  
    Extension 110  
    Termination 110

## O

OPC server 86

## P

PM851 55  
PM851A 55  
PM856/860 55  
PM856A 55  
PM860 25, 55  
PM860A 55  
PM861 55  
PM861A 23  
PM864 55  
PM864A 23  
PM865 55  
PM866 55  
PM891

General 26  
Redundant Configuration 61  
Single Configuration 58  
PM8xx 119  
power  
    External source  
        external power source 35  
Power Supply 34, 102, 126  
Processor Module  
    Redundancy 29  
Processor Unit 23, 55, 119  
    Redundancy 29  
PROFIBUS DP 31, 72, 76, 133, 135  
Profinet 31

## R

RAM 23, 32, 121  
RCU Link Cable 60, 110  
    TK851 110  
    TK855 110  
    TK856 111  
RCU Link Connector 60  
RJ45 134  
RJ45 connectors 86  
RS-232C 31, 56, 74, 125, 134

## S

S100 37  
S100 I/O 31, 36 to 37, 80, 137  
S800 36  
S800 I/O 36  
S900 37  
SD831 102  
SD832 102  
SD833 102  
SD834 102  
SM810 66  
SM811 68  
SS822 151  
SS823 151

**T**

TB820 44  
TB840 37, 61  
TK212 56  
TK575/TK580 37  
TK850 60 to 61  
TK851 60  
TP830 23, 25, 55, 74, 119  
TP851 72, 133  
TP853 74, 78, 82, 134, 136, 138  
TP854 76, 135  
TP855 66  
TP856 37, 80, 137  
TP858 139  
TP860 86, 140  
TP868 68  
TRIO 38  
TRIO Interface CI862 141  
TÜV Approval 15

**U**

UL Listing 15  
UL standards 177



---

# Revision History

## Introduction

This section provides information on the revision history of this User Manual.



The revision index of this User Manual is not related to the 800xA 5.1 System Revision.

## Revision History

The following table lists the revision history of this User Manual.

Revision Index	Description	Date
-	First version published for 800xA 5.1	June 2010
A	Added new contents for AC 800M 5.1.1 and 5.1.0-2	January 2013

## Updates in Revision Index A

The following table shows the updates made in this User Manual for Revision Index A.

Updated Section/Sub-section	Description of Update
Section 2, Functional Description Section 3, Software Components Section 4, Hardware Components Section 6, Technical Data and Performance Appendix A, Power Consumption	Added contents for the new AC 800M controllers - PM851A/PM856A/PM860A.







# Contact us

## **ABB AB**

### **Control Technologies**

Västerås, Sweden

Phone: +46 (0) 21 32 50 00

e-mail: [processautomation@se.abb.com](mailto:processautomation@se.abb.com)

[www.abb.com/controlsystems](http://www.abb.com/controlsystems)

## **ABB Automation GmbH**

### **Control Technologies**

Mannheim, Germany

Phone: +49 1805 26 67 76

e-mail: [marketing.control-products@de.abb.com](mailto:marketing.control-products@de.abb.com)

[www.abb.de/controlsystems](http://www.abb.de/controlsystems)

## **ABB S.P.A.**

### **Control Technologies**

Sesto San Giovanni (MI), Italy

Phone: +39 02 24147 555

e-mail: [controlsystems@it.abb.com](mailto:controlsystems@it.abb.com)

[www.abb.it/controlsystems](http://www.abb.it/controlsystems)

## **ABB Inc.**

### **Control Technologies**

Wickliffe, Ohio, USA

Phone: +1 440 585 8500

e-mail: [industrialitsolutions@us.abb.com](mailto:industrialitsolutions@us.abb.com)

[www.abb.com/controlsystems](http://www.abb.com/controlsystems)

## **ABB Pte Ltd**

### **Control Technologies**

Singapore

Phone: +65 6776 5711

e-mail: [processautomation@sg.abb.com](mailto:processautomation@sg.abb.com)

[www.abb.com/controlsystems](http://www.abb.com/controlsystems)

## **ABB Automation LLC**

### **Control Technologies**

Abu Dhabi, United Arab Emirates

Phone: +971 (0) 2 4938 000

e-mail: [processautomation@ae.abb.com](mailto:processautomation@ae.abb.com)

[www.abb.com/controlsystems](http://www.abb.com/controlsystems)

## **ABB China Ltd**

### **Control Technologies**

Beijing, China

Phone: +86 (0) 10 84566688-2193

[www.abb.com/controlsystems](http://www.abb.com/controlsystems)

Copyright © 2003-2013 by ABB.

All rights reserved.

3BSE036352-510 A

Power and productivity  
for a better world™

