

ABB MEASUREMENT & ANALYTICS | COMMISSIONING INSTRUCTION

ACF5000

Multi-component FTIR analyzer system



Measurement made easy

Contents

Preface	4
Safety instructions	6
Intended use	6
Safety instructions	6
Safety instructions for handling the analyzer system	8
Safety instructions for handling the analyzer system with integrated FID	9
Safety instructions for handling the FTIR spectrometer	10
Safety instructions for working with poisonous gases.....	11
Description of the analyzer system	12
Application and function of the analyzer system	12
Components of the analyzer system	14
Option "Hydrogen monitoring of the analyzer cabinet".....	16
Preparation for installation	18
Selection of the sampling point, installation of the wall tube	18
Requirements for the installation site of the analyzer cabinet.....	20
Sample gas inlet conditions	22
Operating gases and test gases	23
Power supply	25
Dimensions, weights and noise level	27
Scope of supply and delivery	28
Material required for the installation (not supplied)	29
Installation	31
General notices	31
Installing the analyzer cabinet.....	32
Installing the gas sampling probe and filter unit	35
Installing the sample gas line	38
Installing the operating gases.....	40
Connecting the electrical leads	42
Commissioning	45
Recommissioning	45
Maintenance	48
General notices	48
Visual inspection.....	49
Seal integrity test	50
FID: Seal integrity and functional checks	52
Dynamic QR code.....	54
Notify service.....	56
Decommissioning	57
Shutting down the analyzer system.....	57
Packing the analyzer cabinet.....	57
Disposal.....	58

Preface

Content of the commissioning instruction

This commissioning instruction contains all the information necessary for the safe and compliant installation and start-up of the analyzer system.

Information on operation, calibration, configuration and maintenance of the analyzer system is documented in the operating instruction. The operating instruction can be found on the DVD-ROM "Software tools and technical documentation", which is supplied with the gas analyzer (see below).

This commissioning instruction contains information on all functional components of the analyzer system. It is possible that the analyzer system delivered differs from the version described here.

System documentation

The system documentation is supplied together with the analyzer system. It includes:

- Analyzer Data Sheet,
- Commissioning instruction,
- Certificates (e.g., manufacturer declaration),
- DVD-ROM "Software tools & technical documentation" with
 - Software tools,
 - Operating instructions,
 - Data sheets,
 - Technical information,
 - Certificates.
- CD-ROM with the set of drawings prepared specifically for the analyzer system delivered:
 - Component location diagram,
 - Piping diagram,
 - Interface diagram,
 - Wiring diagram,
 - Connection diagram.

Further information

Internet

You can find information on ABB Analytical products and services online at <http://www.abb.de/analytical>.

Service contact

If the information in this commissioning instruction does not cover a particular situation, ABB service will be pleased to supply additional information as required.



Please contact your local service representative. For emergencies, please contact

ABB Service,

Telephone: +49-(0)180-5-222 580, Fax: +49-(0)621-381 931 29031,

E-mail: automation.service@de.abb.com

Identification of safety instructions in this commissioning instruction

 DANGER	If the safety instruction identified in this way is not observed, an accident will occur. This will result in severe bodily injury or death.
 WARNING	If the safety instruction identified in this way is not observed, an accident may possibly occur. This may result in severe bodily injury or death.
 CAUTION	If the safety instruction identified in this way is not observed, an accident is likely to or will definitely occur. This may result in moderately severe or slight bodily injury.
CAUTION!	Denotes information about possible equipment damage when there is no danger to personnel.
NOTICE	Denotes information about particular features with regard to the handling of the analyzer system and the use of this commissioning instruction.

Letters and numbering used in this commissioning instruction

1, 2, 3, ...	Is the way reference numbers are used in the figures.
Display	Is the way information is presented in the display.
Input	Indicates an input by the user <ul style="list-style-type: none"> • either by pressing a softkey • or by selecting a menu item • or via the numeric keypad
p_e	Gauge pressure
p_{abs}	Absolute pressure
p_{amb}	Atmospheric pressure

Safety instructions

Intended use

Intended use

The ACF5000 analyzer system is designed for continuous measurement of the concentration of individual components in gases or vapors.

Any other use is not approved.

The intended use also includes taking note of this commissioning instruction.

The analyzer system may not be used for the measurement of ignitable gas/air or gas/oxygen mixtures during normal service. The analyzer system may not be set up in potentially explosive atmospheres.

In normal service, the interior of the analyzer system contains no potentially explosive atmosphere. Accordingly, installation of explosion protection in the interior is not necessary for operation of the analyzer system.

Safety instructions

Requirements for safe operation

In order to operate in a safe and efficient manner the device should be properly handled and stored, correctly installed and set-up, properly operated and correctly maintained.

Personnel qualifications

Only persons familiar with the installation, commissioning, operation and maintenance of comparable devices and certified as being capable of such work should work on the device.

Special information and precautions

These include

- The content of this commissioning instruction,
- The safety instructions affixed to the device,
- The applicable safety precautions for installing and operating electrical devices,
- Safety precautions for working with gases, acids, condensates, etc.

National regulations

The regulations, standards and guidelines cited in this commissioning instruction are applicable in the Federal Republic of Germany. The applicable national regulations should be followed when the device is used in other countries.

Device safety and safe operation

The device is designed and tested in accordance with safety standard EN 61010 Part 1 "Safety requirements for electrical equipment for measurement, control, and laboratory use," and is shipped ready for safe operation.

To maintain this condition and to assure safe operation, read and follow the safety instructions in this commissioning instruction. Failure to do so can put persons at risk and can lead to device damage as well as damage to other systems and devices.

Protective conductor terminal

The protective ground conductor should be attached to the protective conductor terminal before any other connection is made.

Danger of a disconnected protective ground conductor

The device can be hazardous if the protective ground conductor is interrupted inside or outside the device or if the protective conductor terminal is disconnected.

Dangers involved in opening the covers

Current-bearing components can be exposed when the covers or parts are removed, even if this can be done without tools. Current can be present at some connection points.

Dangers involved in working with an open device

All work on a device that is open and connected to power should only be performed by trained personnel who are familiar with the dangers involved.

When safe operation can no longer be assured

If it is apparent that safe operation is no longer possible, the device should be taken out of operation and secured against unauthorized use.

The possibility of safe operation is excluded:

- If the device is visibly damaged,
- If the device no longer operates,
- After prolonged storage under adverse conditions,
- After severe transport stresses.

Safety instructions for handling the analyzer system

⚠ WARNING

The warning symbols affixed to the analyzer system must be observed:



Heed the commissioning instruction!



Hot surface! (Temperature > 60°C)



Danger of electric shock!

The following must also be observed:

- The safety instructions for handling the analyzer system with integrated VOC analyzer (see page 9),
- the safety instructions for handling the FTIR spectrometer (see page 10), and
- the safety instructions for working with poisonous gases (see page 11).

⚠ WARNING

The gas paths in the analyzer system and the integral analyzer must not be opened! The gas paths can become leaky as a result.

If the gas paths inside the analyzer system must nevertheless be opened, it is essential that they be subjected to a leak test after being closed again.

Safety instructions for handling the analyzer system with integrated FID

Safety measures

If an FID (VOC analyzer) is installed in the analyzer system, the following safety measures are taken at the factory to ensure safe operation:

- Installation of a hydrogen flow restrictor in the cabinet wall (bulkhead fitting with an integrated flow restrictor, max. 10 l/h, for connection to the combustion gas line),
- Use of stainless steel piping, compression fittings and valves,
- Shutoff of the hydrogen supply in the event of malfunctions,
- Check of the combustion gas paths for leaks inside the analyzer cabinet,
- Installation of pressure equalization fittings on the top of the cabinet to allow escape of hydrogen to the outside in the event of leaks.

As an additional safety measure, the analyzer system can be equipped with the option “Hydrogen monitoring of the analyzer cabinet” (see page 16)

⚠ WARNING

The combustion gas path in the analyzer cabinet and especially in the integral FID must not be opened! The combustion gas feed path can become leaky as a result!

If the combustion gas path inside the analyzer cabinet nevertheless is opened, it is essential that it be subjected to a leak test with a hydrogen leak detector after it is closed again!

The bulkhead fitting with integral flow restrictor for connection of the combustion gas line is a safety-relevant component. It may be replaced only by certified service personnel.

The integrity of the combustion gas path in the analyzer system as well as the combustion gas feed line must be checked prior to commissioning as well as regularly during operation.

Combustion gas that escapes from leaks in the gas paths can cause fires and explosions, even outside the analyzer system!

Sufficient ventilation must be provided at the installation site of the analyzer system.

Safety instructions for handling the FTIR spectrometer

Central unit with electronics module (power supply):

The FTIR spectrometer has an unprotected metal housing that is connected directly to ground potential via the power cable and is thus classified as "Safety Class 1 Equipment".

⚠ WARNING	Before fuses are replaced, the device must be disconnected from the power supply.
	To avoid electric shock, the device may not be operated if there is an indication that any part of the outer surface is damaged.
⚠ CAUTION	To protect against fires, only a fuse of the specified type and current rating may be used.
	To protect against electric shock, the protective ground conductor of the power cable must be connected to ground potential.
CAUTION!	The device must not be exposed to any source of the excessive moisture. The device may not be used in an explosive hazardous atmosphere.
NOTICE	Approval from the responsible authorities is required for measurement of combustible gases.

Laser safety

Under normal conditions, the FTIR spectrometer can be operated completely safely (Class 1 laser product – see name plate).

	<p>Type of laser installed in the interferometer: Class 3B VCSEL laser to IEC 60825-1 as well as 21 CFR Chapter 1, Subchapter J</p> <p>Output: max. 3 mW</p> <p>Wavelength: 760 nm (laser beam invisible to the human eye)</p>
⚠ WARNING	The housing of the interferometer AU3 may not be opened during normal operation. It contains no user-operated parts.
	The housing of the interferometer may be opened only by authorized ABB service personnel.
⚠ DANGER	Opening the housing of the interferometer AU3 and the interferometer module in particular can result in contact with laser radiation.
	Radiation from Class 3B lasers poses a danger to the human eye both when viewed directly and if reflected.

Safety instructions for working with poisonous gases

▲WARNING

Some gas components whose concentration is measured with the analyzer system are hazardous to health or poisonous.

For this reason, the sample gas must under no circumstances be allowed to escape from the sample gas path in either the measurement mode or when performing maintenance.

The analyzer system must be checked for leaks regularly.

The diluted stack gas must be discharged outside the room where the analyzer cabinet is installed.

Ensure adequate ventilation of the room in which the analyzer system is installed.

The legal requirements for the maximum work place limit values of the measurement and test gases must be observed.

Description of the analyzer system

Application and function of the analyzer system

Application

The ACF5000 analyzer system is a multi-component analyzer system for continuous measurement of the concentration of individual components in the flue gas of industrial incinerators.

The field of application of this measuring equipment basically involves tasks associated with emissions monitoring; use in process control applications, however, is also possible.

Function

The gas to be measured is drawn from the gas channel by means of a gas sampling probe and conveyed to the analyzer cabinet via a heated sample gas line. The sampling probe contains a particulate filter that removes dust particles from the gas. As a standard feature, the analyzer system controller offers the ability to connect the zero gas and test gas to the sampling probe upstream of the filter element automatically. Automatic cleaning of the sampling probe filter is available as an option.

The gas path from the sampling location to the analyzer is heated throughout (180°C) to prevent the temperature from dropping below the dew point or condensation of flue gas. The heating is controlled and monitored by the system's electronics.

An optional heated measuring point selector can be configured for process measurements.

Conveying of the sample to the analyzer is based on the injector principle and employs an air jet injector that is integrated into the heated sample handling block (ASP block). This, in turn, is connected directly to the heated gas cell.

Test gases can be connected either automatically or manually to both the gas sampling probe and directly to the analyzer.

Measuring principle

The analyzer system operates on the principle of FTIR spectrometry. The concentrations of a variety of stack gas components that exhibit absorption bands in the mid-infrared range can be determined.

Each gas absorbs infrared radiation in a specific region of the spectrum. The radiation absorbed at a given wavelength is a function of the gas concentration. The FTIR analyzer (spectrometer) measures how much radiation was absorbed at specific wavelengths.

The information about the absorption processes is processed in the system's electronics and converted into measured values. At the same time, the spectra of all components are recorded.

A zirconium dioxide sensor for measurement of the oxygen content is an integral part of the analyzer system.

Options

Validation

A validation unit can be installed in the beam path of the spectrometer to confirm the validity of the spectrometer adjustment.

Total carbon measurement

A flame ionization detector (FID) for measurement of the total carbon content (VOC) can be incorporated into the analyzer system.

Display and signal processing

The current concentration of the individual measured components and the status signals are shown on the system display.

The system controller has been designed for the requirements of emissions and process measurement. It offers a system-internal CAN bus and field bus systems such as Modbus and PROFIBUS as interfaces. An Ethernet interface for remote monitoring of the entire analyzer system and transmitting data via internal or external TCP/IP networks is included. Remote control of the analyzer system is possible via a UMTS router. Analog outputs for the measured components and relay contacts for fault/status messages are optional.

Components of the analyzer system

NOTICE

A delivered analyzer system may not include certain individual assemblies described in this section depending on the measurement task and execution ordered.

Assemblies in the analyzer cabinet

- AU1** ACF5000 E-box
- AU2** Analyzer box
- AU3** Interferometer box
- AU4** FTIR E-box
- AU5** Air purifier

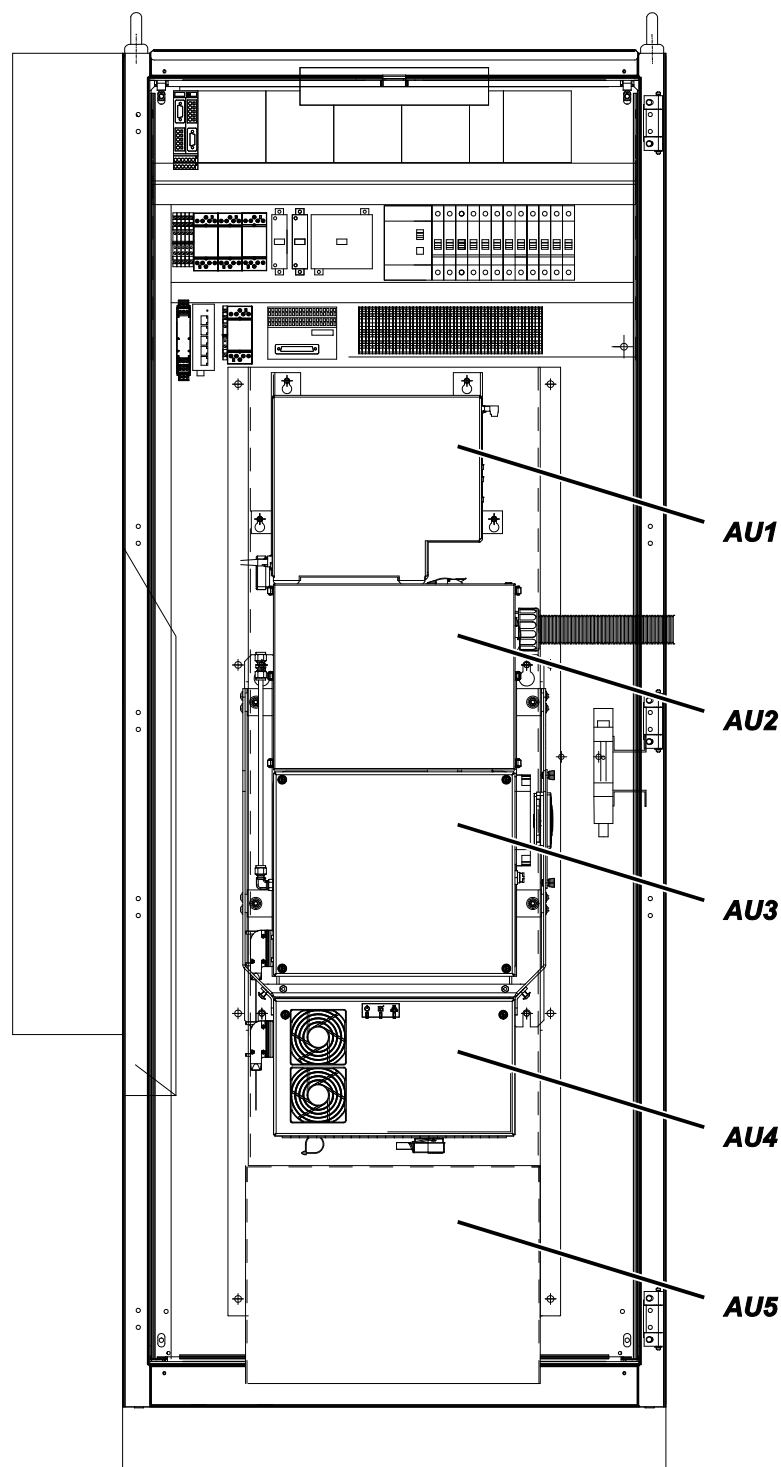

Gas sampling

- Stainless steel probe tube, unheated (Type 40) or heated (Type 42)
- Filter unit, heated (Type PFE2), with check valve, with back-purging (option)
- Sample gas line, heated (Type TBL01)
- Heated selector valve for switching between two sampling points (option)

CAUTION!

For measurement gas sampling, only the assemblies specified by ABB may be used, as both the temperature controls and the securing functions are aligned to this.

Sample gas conditioning

- Sample gas conditioning block (ASP block), heated, with stainless steel microfilter and air jet injector
- Automatic purge and test gas switching
- Flow rate, pressure and temperature sensors

Air preparation

- Zero air for the spectrometer and end point gas for the oxygen sensor and combustion air for the FID
- Purge gas for the spectrometer and the entire measuring system

Analyzers

- FTIR spectrometer with heated measuring cell
- Oxygen sensor (ZrO₂ sensor)
- Flame ionization detector (FID, option)

Control, operation and display

- Display and control unit in the door of the analyzer cabinet
- AO2000 system controller in the door of the analyzer cabinet
- ACF5000 electronics box AU1
- Controls for the air jet injector as well as the oxygen sensor and FID
- Interfaces for
 - measured values and status signals (standard: Ethernet with TCP/IP protocol and Modbus TCP/IP protocol, options: Modbus, PROFIBUS, analog and digital outputs, analog and digital inputs)
 - Remote control and diagnosis (modem and/or Ethernet)

For emission measurements in compliance with applicable European Directives, the analyzer system must be operated with certified AO2000 system software.

Option "Hydrogen monitoring of the analyzer cabinet"

Function

The "Hydrogen monitoring of the analyzer cabinet" option is an additional safety measure when an FID analyzer is built-in in the analyzer system. If a leak occurs in the hydrogen path inside the analyzer cabinet and hydrogen accumulates inside the cabinet, both the hydrogen supply and the power supply are shut off before the explosion limit is reached – at 40% LEL. This prevents formation of an ignitable mixture.

Scope of supply and delivery

Installed in the analyzer cabinet:

- In the upper area, an ATEX-certified gas sensor with connection socket,
- Outside on the right side wall, a solenoid valve that interrupts the hydrogen supply at 40% LEL and at power supply failure (H₂ safety valve).

Also supplied:

- A gas warning center for evaluating the gas sensor signal,
- A contactor for disconnecting the power supply to the analyzer cabinet,
- A contactor for disconnecting the UPS if the system is prepared for a UPS.

Installation

The electrical wiring of the gas sensor and the gas warning center for switching off the power supply in the event of an alarm has not yet been completed in the factory delivered condition of the analyzer system.

The gas warning center must be installed outside the analyzer cabinet in a non-hazardous area in a distribution cabinet or similar. It must be electrically connected to the gas sensor (see the order-specific set of drawings in this regard).

The solenoid valve for disconnecting the hydrogen supply as well as the coils of the contactors and relays for disconnecting the power supply and UPS (if present) must be connected to a fault-signaling contact in the gas warning center. The fault-signaling contact must be set so that the voltage is shut off at 40% LEL and the contact itself latches.

The measuring signals (analog outputs and inputs), the status signals (digital outputs and inputs) as well as the bus systems of the analyzer system are so designed that after the power supply (and possibly the UPS) are disconnected no component in the analyzer cabinet (contactor, relay, motor etc.) that could generate an ignition spark can be actuated from the outside.

Potential-free measurement and status signals as well as bus connections do not have to be disconnected separately in the event of a gas alarm. If, however, an external signal that is not potential-free is fed in, the operator must ensure that it is shut-off when the gas alarm is triggered, e.g. via an isolating relay.

NOTICES

The gas sensor installed in the analyzer cabinet is not calibrated at the factory; it is not functional without calibration. The calibration of the gas sensor is the responsibility of the operator.

Installation, commissioning, parameterization, operation, signal evaluation and maintenance of the supplied gas warning center are the responsibility of the operator.

 WARNING

If the above-mentioned instructions are not observed or the hydrogen monitoring of the analyzer cabinet is installed incorrectly, a hydrogen explosion may occur in the event of a malfunction.

Preparation for installation

Selection of the sampling point, installation of the wall tube

Selection of the sampling point

- The sampling point must be suited for extracting a representative sample stream.
- The probe tube must be readily accessible for maintenance work.
- The PFE2 filter unit must be protected from direct exposure to heat and soiling. The protective enclosure provides protection class IP54.

NOTICE

In compliance with DIN EN 15259, the sampling point for emission measuring equipment is specified by the responsible entities accredited in accordance with DIN EN ISO/IEC 17025.

Installation of the wall tube with mounting flange

The wall tube with mounting flange (DN 65, PN 6, facing type A to DIN EN 1092-1; not included with delivery) should be installed at the sampling point such that the probe tube can be inserted and withdrawn without difficulty.

Installation of the wall tube in brickwork (dimensions in mm):

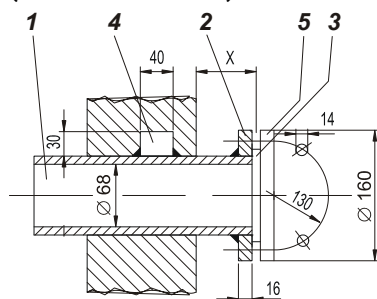

Installation of the wall tube in brickwork with metal sheeting (dimensions in mm):

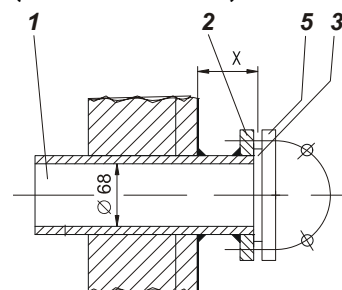

Installation of the wall tube in an insulated sheet-metal channel (dimensions in mm):

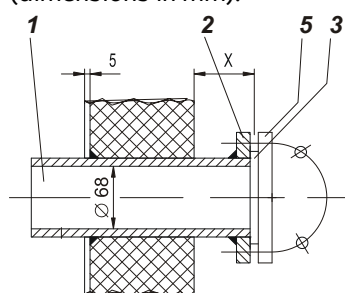

- | | |
|---|---|
| 1 | Wall tube |
| 2 | Assembly flange DN 65, PN 6, facing type A to DIN EN 1092-1 |
| 3 | Gasket |
| 4 | Welded-on rectangular block |
| 5 | Sampling probe flange |

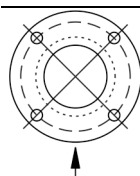

The figure shows an image of the flange as viewed from the process to the filter. The arrow indicates the flow direction of the process gas.

Select the mounting position of the wall tube so that the holes are located in the position shown here.

Minimum distance x_{min} of the mounting flange on the wall tube from the wall as a function of installation angle α :

Installation angle α	10°	15°	20°	25°	30°	35°
x_{min}/mm	229	248	268	287	307	324

Requirements for the installation site of the analyzer cabinet

Short gas paths

- The analyzer cabinet should be set up as close as possible to the measuring location. A short sample gas line translates into short dead times.
- Because of the pressure drop in the line and the required electrical protection, the length of the heated sample gas line must not exceed 60 meters when connected to 230 VAC and 40 meters when connected to 120 VAC. Depending on the altitude of the installation site, these values may be lower.
- The test gas bottles should be set up as close as possible to the analyzer cabinet.

Protection from adverse ambient conditions

- The analyzer cabinet must be protected from
 - Jets of water,
 - Contact with chemicals,
 - Strong sunlight and heat,
 - Strong air currents
 - Extremely dusty environments,
 - Corrosive atmosphere
 - Vibration.

Climatic conditions

- Ambient temperature for storage and transport -25 to +65°C
- Ambient temperature during operation
 - with built-in fan (option) +5 to +30°C
 - With built-in air conditioner (option) +5 to +45°C
- Relative humidity during operation
 - Annual average max. 75%
 - briefly max. 95%
- seldom and slight condensation permissible if the analyzer system is switched on and the FTIR spectrometer is purged

NOTICE

The analyzer cabinet should be packaged during storage and transport!

Installation site

CAUTION!

The analyzer cabinet may not be set up in potentially explosive atmospheres!

The analyzer cabinet is intended solely for installation indoors.

The maximum altitude of the installation site is 720 m above sea level (for up to 60 m longer sample gas line with probe).

Note: The minimum inlet pressure at the analyzer cabinet is 900 hPa. This results in a maximum installation site height of 720 m. Higher altitudes would result in insufficient gas flow through the system. The inlet pressures for the ACF5000 may not be lowered, as this directly reduces the sensitivity of the FTIR spectrometer. As a consequence, the measuring accuracy and drift in accordance with QAL1, QAL2, and QAL3 for components with a low concentration cannot be assured.

Space requirement

- to the right 0.5 m for the gas lines and the electrical lines as well as for air entry into the fan (option)
- to the left 0.5 m for air discharge from the fan (option)
1 m for the air conditioner (option)
- at the front 1 m for opening the door (hinged on the left)
- above 0.5 m

⚠ WARNING

The pressure equalization fittings in the top of the analyzer cabinet may not be closed in any event. The openings are necessary in order to prevent any accumulation of poisonous or combustible gases in the cabinet in the event of leaks.

Floor

The floor at the installation site must be level and strong enough to support the weight of the analyzer cabinet (approx. 300 kg).

Sample gas inlet conditions

WARNING	The analyzer system may not be used for the measurement of ignitable gas/air or gas/oxygen mixtures during normal service.
CAUTION!	<p>The analyzer system may not be used for the measurement of gases containing organometallic compounds, e.g. lead-containing fuel additives or silicone oils.</p> <p>If the analyzer system is used to measure HF, all seals in contact with the sample gas must be made of FFKM. This applies also and particularly in the case of a gas sampling probe with filter and a sample gas line delivered separately.</p>
NOTICE	The seals in the analyzer system that come into contact with the sample gas generally consist of FFKM.

Sample gas inlet conditions

Temperature	Controlled to $180 \pm 2^\circ\text{C}$ by means of the heated sample gas line
Inlet pressure	Analyzer cabinet inlet leading to the sample gas handling block: $p_{\text{abs}} = 900$ to 1100 hPa (0.9 to 1.1 bar)
Flow rate	80 to 300 l/h

Operating gases and test gases

FTIR spectrometer

Zero air:

Quality	Clean compressed air from the air purifier
Inlet pressure	$p_e = 2000 \pm 100$ hPa (2.0 ± 0.1 bar)
Flow rate	max. 500 l/h

Span gas:

Quality	Measured component in N ₂ , 70 to 80% of the measuring range (accuracy $\pm 2\%$)
Inlet pressure	$p_e = 1500 \pm 100$ hPa (1.5 ± 0.1 bar)
Flow rate	max. 500 l/h

NOTICE

The test gases H₂O, HCl, HF, and NH₃ are produced by a vapor generator through vaporization of distilled water, HCl, HF, or NH₃ solutions with known concentrations.

WARNING

Test gases for the FTIR spectrometer may only be issued by trained service personnel. In the event of a leak in the components for the test gas task, there is a risk of poisoning when opening the analyzer cabinet. Before opening the cabinet, the test gas supply therefore needs to be shut-off and the leakproofness of the test gas line verified by observing the pressure on the manometer. The leakproofness is ensured only if the pressure remains constant.

FID

Combustion air: Clean compressed air from the air purifier is used as combustion air.

Combustion gas:

Quality	H ₂ , quality 5.0
Inlet pressure	$p_e = 1200 \pm 100$ hPa (1.2 ± 0.1 bar)
Flow rate	approx. 4 l/h

NOTICE

Provide two 40-l bottles and a selector station. A flow restrictor that limits the combustion gas flow rate to 10 l/h is installed in the bulkhead fitting for connection of the combustion gas line.

Zero gas:

Quality	N ₂ , quality 5.0
Inlet pressure	$p_e = 1500 \pm 100$ hPa (1.5 ± 0.1 bar)
Flow rate	max. 500 l/h

Span gas:

Quality	n-Propane C ₃ H ₈ in N ₂ , 70 to 80% of the measuring range (accuracy $\pm 2\%$)
Inlet pressure	$p_e = 1500 \pm 100$ hPa (1.5 ± 0.1 bar)
Flow rate	max. 500 l/h

NOTICE

Since the FID analyzer measures only the number of C atoms, the concentration of the zero gas must be converted from ppm or mg/m³ C_n H_m into ppm or mg/m³ C.

Oxygen sensor

Zero gas:

Quality	3 vol.% O ₂ in N ₂ (accuracy ±2%)
Inlet pressure	p _e = 1500 ± 100 hPa (1.5 ± 0.1 bar)
Flow rate	max. 500 l/h

Span gas:

Quality	Clean compressed air (20.96 vol.% O ₂) from the air purifier
Inlet pressure	p _e = 1500 ± 100 hPa (1.5 ± 0.1 bar)
Flow rate	max. 500 l/h

Instrument air

Quality	On the basis of ISO 8573-1:2001 class 2 (max. particle size 1 to 5 µm, max. 10 particles/m ³ , max. oil content 0.1 mg/m ³ , max. vapor pressure dew point -40°C)
Inlet pressure	p _e = 5500 to 7000 hPa (5.5 to 7.0 bar)
Flow rate	In normal mode 3000 to 3800 l/h, during adjustment briefly up to 5000 l/h

NOTICE Install a pressure controller and a shut-off fitting in the instrument air feed as close as possible to the installation site of the analyzer cabinet.

Compressed air for back-purging

Quality	Instrument air
Inlet pressure	max. 6 bar for back-purging, approx. 4 bar as control air (needed for 2-stage back-purging with Type PFE2 filter unit and with FID)
Flow rate	approx. 1600 l/min (duration of the back-purging procedure approx. 45 seconds)

NOTICE Compressed air is needed to clean the sampling filter and the probe tube as well as for controlling the control valves.

Definition

p_e = p_{abs} - p_{amb} with p_e = gauge pressure, p_{abs} = absolute pressure, p_{amb} = atmospheric pressure

Power supply

Power supply

Voltage	230/400 VAC, 3 phases ¹⁾ or 120/208 VAC, 3 phases ¹⁾ or 100/200 VAC, 3 phases (via transformer), ± 10%, 48 to 62 Hz	
Fuse (external)	3 x 20 A or 3 x 25 A	
Power consumption	approx. 2200 VA, approx. 1500 VA	during power-up, during operation
	+ approx. 800 VA	for heated probe tube
	+ approx. 250 VA	for heated filter unit
	+ approx. 90 VA/m	for heated sample gas line
	+ approx. 1000 VA	for air conditioner
	+ approx. 350 VA	for heated selector valve with "2nd measuring location" option

1) L1, L2, L3, N, PE, current-carrying neutral is not allowed.

Uninterruptible power supply (UPS)

The option "prepared for UPS" is not possible in the case of a 100 VAC power supply.

Voltage	230 VAC, 1 phase ¹⁾ or 120 VAC, 1 phase ¹⁾ , 48 to 62 Hz	
Fuse (external)	20 A	
Power consumption	approx. 500 VA (incorporated into above values)	

1) L, N, PE, current-carrying neutral is not allowed.

Service socket

230 VAC or 120 VAC, 48 to 62 Hz, max. 5 A.

The service socket is located in the cabinet light fixture.

Fuses

	Function	Rated value
-F80	Supply ground-fault circuit interrupter	30 A/30 mA
-F81	Fan or air conditioner (option)	6 A or 16 A at 230 V, 20 A at 120 V
-F82	Lighting, service socket	6 A
-F83	Type 42 probe tube heater, PFE2 filter unit heater, back-purging valves	6 A (only PFE2) or 10 A (PFE2 + probe 42, 230 V) or 16 A (PFE2 + probe 42, 120 V)
-F84	Heated sample gas line	16 A
-F85	ACF5000 electronics box AU1, ASP block heater, gas cell heater	6 A
-F86	Air purifier, FTIR spectrometer, flow monitor, system controller, power supply unit 24 V/5 A	6 A
-F87	Option "2nd measuring location": Type 42 probe tube heater, PFE2 filter unit heater, back-purging valves	6 A (only PFE2) or 10 A (PFE2 + tube 42, 230 V) or 16 A (PFE2 + tube 42, 120 V)
-F88	Option "2nd measuring location": heated sample gas line	16 A
-F89	Option "2nd measuring location": heated selector valve and heated sample gas line to analyzer cabinet	6 A
-F90	UPS supply ground-fault circuit interrupter	25 A/30 mA
-F91 to -F99	Relay coils, contactor coils, solid-state relays, selector to solenoid valve (ceramic fuses)	T 2 A

CAUTION

High leakage current: 9 mA!

Dimensions, weights and noise level

Dimensions

see "Location diagram" in the system documentation

Weights

Analyzer cabinet		approx. 300 kg
Type 40 probe tube (unheated) depends on length	500 mm	1 kg
	1000 mm	2 kg
	1500 mm	3 kg
	2000 mm	4 kg
	2500 mm	5 kg
Type 42 probe tube (heated) depends on length	1000 mm	8 kg
	1500 mm	10 kg
	2000 mm	12 kg
Type PFE2 filter unit, heated, with protective enclosure		20 kg
Type TBL01 sample gas line, heated		1 kg/m
System transformer from 100 V to 230 V		42 kg
Electrical distribution cabinet for "2nd measuring location" option		60 kg
Heated selector valve for "2nd measuring location" option		8 kg

Noise level

Fan	50 Hz	59 dB(A)
	60 Hz	61 dB(A)
Air conditioner		70 dB(A)

Scope of supply and delivery

Standard scope of supply and delivery

Qty.	Description
1	Analyzer cabinet (all components installed)
1 set	system documentation

Included with delivery if ordered

Qty.	Description
1	Type 40 (unheated) or Type 42 (heated) gas sampling probe
1	Type PFE2 filter unit, heated
1	Type TBL01 sample gas line, heated
1	System transformer, 100 V to 230 V (option)

2nd measuring location option

Qty.	Description
1	Type 40 (unheated) or Type 42 (heated) gas sampling probe
1	Type PFE2 filter unit, heated
1	Type TBL01 sample gas line, heated
1	Heated selector valve
1	Heated sample gas line to analyzer cabinet
1	Electrical distribution cabinet for 2nd measuring location

"Hydrogen monitoring of the analyzer cabinet" option

Qty.	Description
1	Gas warning center Unipoint
1	Contactator for disconnecting the power supply to the analyzer cabinet
1	Contactator for disconnecting the UPS if the system is prepared for a UPS
1	Unipoint Multilingual Manual CD
1	Sensepoint Manuals CD

NOTICE The gas sensor and the H₂ safety valve are installed in the analyzer cabinet.

Material required for the installation (not supplied)

Gas sampling

Wall tube with mounting flange (DN 65, PN 6, facing type A to DIN EN 1092-1)

Gas lines

Instrument air	1 tube or compressed-air hose, O.D. 8 mm or $\frac{3}{8}$ in. (with pressure regulator and shut-off fitting)
Combustion gas for the FID	1 extremely clean (hydrocarbon-free) stainless steel tube (SS316), O.D. 6 mm (ABB item no. 0017400, length = 6 m) or $\frac{1}{4}$ in. 1 two-stage cylinder pressure reducer (designed for high-purity gases) with flow restriction
Test gas for FTIR	1 PTFE tube 4/6x1 mm or $\frac{1}{8}$ in./ $\frac{1}{4}$ in.
Test gas O ₂ measurement	1 PTFE tube 4/6x1 mm or $\frac{1}{8}$ in./ $\frac{1}{4}$ in.
Test gases for VOC measurement	2 PTFE tubes 4/6x1 mm or $\frac{1}{8}$ in./ $\frac{1}{4}$ in.
Test gases for drift check	3 PTFE tubes 4/6x1 mm or $\frac{1}{8}$ in./ $\frac{1}{4}$ in.
Purge gas for sampling	1 PTFE tube 4/6x1 mm or $\frac{1}{8}$ in./ $\frac{1}{4}$ in., length about the same as the sample gas line
Waste gas	1 hose, O.D. 12 mm or $\frac{1}{2}$ in. Pressure reducer for high-purity gases

Power supply lines

Power supply	5 x 6 mm ² in compliance with DIN EN 61010-1 or 5 x AWG8
UPS (option)	3 x 2.5 mm ² or 3 x AWG14
Connecting cables	for the connections from the analyzer cabinet to the heated gas sampling probe, filter unit, and sample gas line (possibly in temperature-resistant design; take the power consumption of these components into account) <ul style="list-style-type: none"> • Probe tube type 42: 3 x 1.5 mm² or 3 x AWG16 • Filter device PFE3: 3 x 1.5 mm² or 3 x AWG16 • Backflush for filter device PFE3: 8 x 1.5 mm² or 8 x AWG16 • Sample gas line TBL01 1-phase: 3 x 2.5 mm² or 3 x AWG14 • Sample gas line TBL01 3-phase: 5 x 2.5 mm² or 5 x AWG14
Grounding cable	≥ 10 mm ² or AWG6

NOTICE When selecting the cable material, observe the applicable national safety requirements for installing and operating electrical equipment.

Signal lines

Analog outputs	Shielded cables for the analog outputs (current outputs): 2 x 0.5 mm ² or 2 x AWG20 per analog output
Analog inputs	Shielded cables for the analog inputs (current inputs with the option "external analog inputs"): 2 x 0.5 mm ² or 2 x AWG20 per analog input
Digital outputs	Cables for the digital outputs: 5 x 0.5 mm ² or 5 x AWG20 per group of 4 digital outputs
Digital inputs	Cables for the digital inputs (with the option "external digital inputs"): 2 x 0.5 mm ² or 2 x AWG20 per digital input
Data lines	Cables for the data lines (Modbus, PROFIBUS, Ethernet), possibly fiber-optic cables for longer transmission distances. On the right side wall of the analyzer cabinet, connectors for the direct connection of assembled data cables can be found (Sub-D 9-pin or RJ45 or M12 panel feed-through 5-pin or 8-pin).
Resistance thermometer	Cables for the Pt 100 resistance thermometers in the heated components; 3 x 0.75 mm ² or 3 x AWG20 per temperature sensor

NOTICE

When selecting the cable material, observe the applicable national safety requirements for installing and operating electrical equipment.

Assembly

Bolts and nuts for fastening the analyzer cabinet to the floor (see "Location diagram in the system documentation)

Installation

General notices

- It is recommended that the analyzer system be installed by ABB.
- In addition to this commissioning instruction, refer to the order-specific set of drawings as well as the operating instructions and data sheets for the individual devices and components when installing the analyzer system.
- If there is shipping damage which indicates improper handling, file a damage claim with the shipper (rail, mail, or freight carrier) within seven days.
- Ensure that the enclosed accessories are not lost (see "Scope of supply and delivery", see page 28).
- Retain the packaging material and the transport protection for possible future transport.

Installing the analyzer cabinet

NOTICE

It is strongly recommended to have the analyzer cabinet

- transported by a qualified company
- while the cabinet is lying on its back as long as possible and
- to stand it up only immediately prior to installation!

Providing the foundation

- Refer to the "Requirements for the installation site" (see page 20)
- Observe the "Arrangement diagram" in the system documentation.
- Provide concrete base with cast-in stud bolts (M10) or iron base frame with holes or grate (see following image, dimensions in mm (inch)).

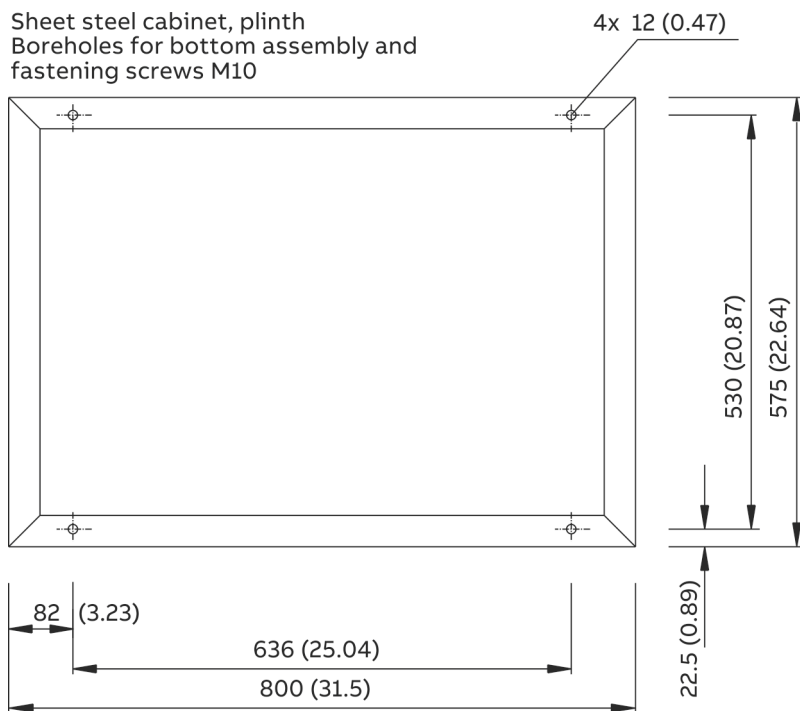

Unpacking the analyzer cabinet

CAUTION

The analyzer cabinet weighs approx. 300 kg! A crane with suitable transport gear is required for unpacking and transporting!

To attach the towing ropes to the analyzer cabinet, use the provided transport lugs.

The pull ropes must be long enough to ensure a minimum angle of 60° when under tension! Otherwise, the analyzer cabinet may warp.

- 1 Open the transport case and take out the analyzer cabinet.
- 2 Do not remove the plastic film in which the analyzer cabinet is wrapped for the time being! Unpacking the analyzer cabinet when cold can cause condensation.
- 3 Remove the plastic film only when the analyzer cabinet has reached room temperature. This takes at least 24 hours.

Installing the analyzer cabinet

- Refer to the "Requirements for the installation site" (see page 20)
- Provision the "Required material" (see page 29).
- Observe the "Arrangement diagram" in the system documentation.
- Grounding via central grounding screw, route grounding cable ($\geq 10 \text{ mm}^2$, AWG6 with "CSA version" option) through the M16 cable gland provided in the right-hand cabinet wall for this purpose.

Removing transport protection in the analyzer unit

NOTICE

Removing the transport protection immediately before commissioning the analyzer system is highly recommended.

Removing the transport protection of the ASP block

The ASP block is fastened using a M8x80 transport protection bolt. This is routed from above through a hole in the housing of the ACF5000 electronics box AU1 and screwed into the ASP block.

- 1 Open the cover of the ACF5000 electronics box and take it out.
- 2 Using a 13 mm spanner, undo the transport protection bolt **1** and remove it together with the washer.

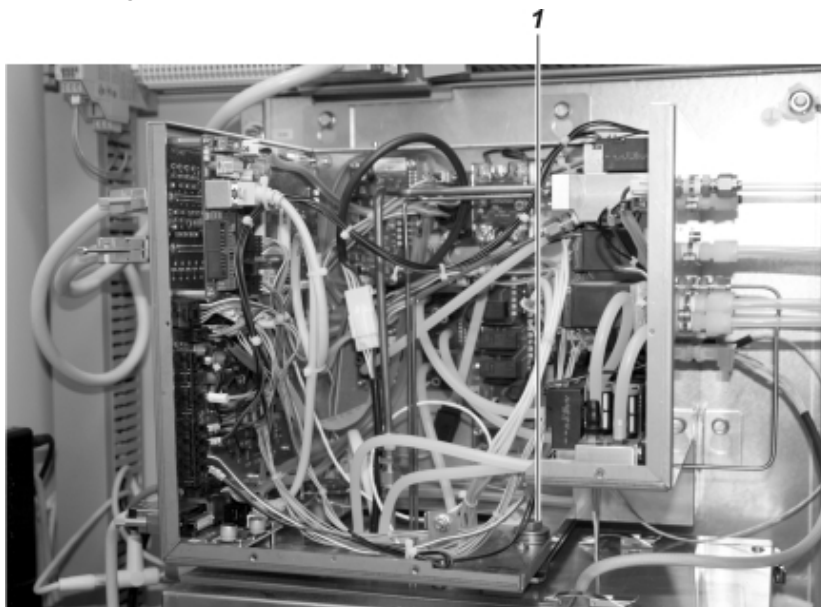

- 3 Remount the cover of the ACF5000 electronics box and close it.
- 4 Keep the transport protection bolt together with the washer for transporting at a later time.

"2nd measuring location" option

Installing the electrical distributor cabinet

The electrical distributor cabinet for connecting the 2nd measuring location must be installed as close to the analyzer cabinet as possible.

On the analyzer cabinet, cables of about 5 m in length are applied for connection to the electric distribution cabinet.

Installing the heated switchover valve

The heated 3/2-way solenoid valve for switching between the two measuring locations must be assembled as close to the analyzer cabinet as possible.

The sample gas lines from the two sampling points and the 1.5 m sample gas line to the analyzer cabinet must be connected to the switchover valve. During installation of the sample gas lines, the information in the section "Installing the sample gas line" (see page 38) must be observed.

Installing the gas sampling probe and filter unit

Installing the gas sampling probe and filter unit

- Observe the "Piping diagram" in the system documentation.
- Install the gas sampling probe and filter unit:

CAUTION

The pre-assembled probe tube with filter unit weights approx. 17 to 32 kg, depending on the version! Two persons are required for the transporting and assembly operations!

- Probe tube 40: Insert pre-assembled probe tube with filter unit into the wall tube and screw the assembly flange to the filter device flange.
- Heated probe tube type 42: Insert probe tube into the wall tube and screw up to the assembly flange. Screw filter unit up to the flange.
- Connect the electrical leads on the gas sampling probe and filter unit as per the "Wiring diagram" and "Terminal diagram" in the system documentation.
- Local grounding: Connect the heated special tube and the filter device at the collection point with a large cross-section ($\geq 10 \text{ mm}^2$ or $\geq \text{AWG7}$) on the potential equalization.

Assembling the probe's protective case with the filter unit PFE2

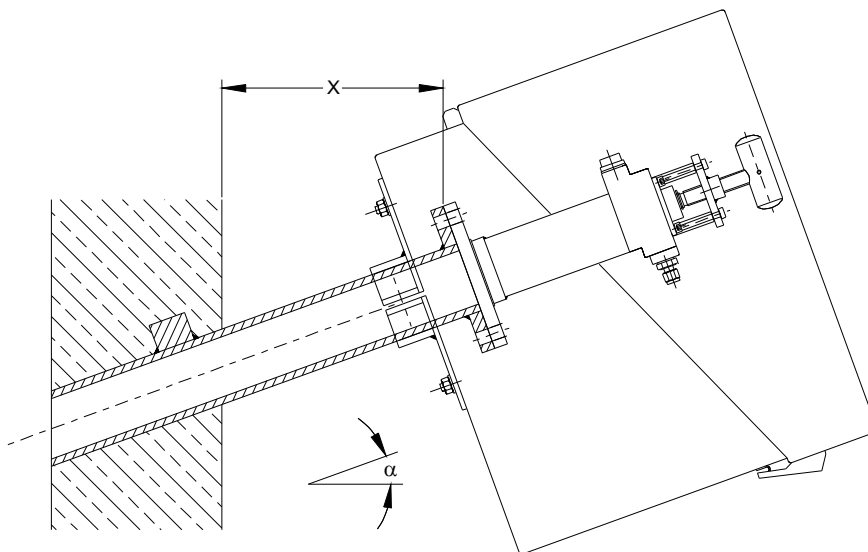

Installation angle α	10°	15°	20°	25°	30°	35°
x_{\min}/mm	229	248	268	287	307	324

Gas connections of PFE2 Filter unit

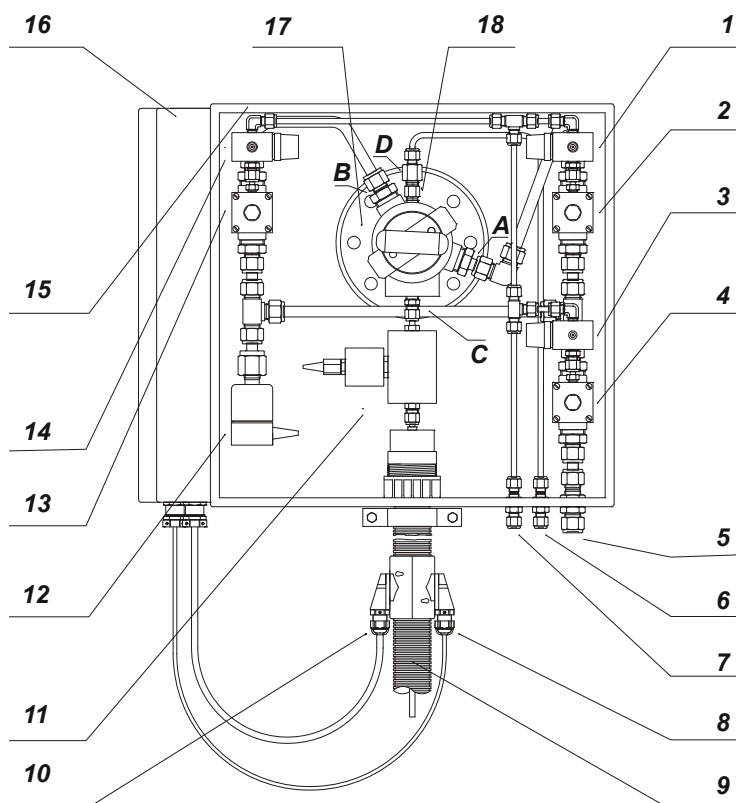

1	Pilot valve for cleaning filter -Y2.1
2	Diaphragm valve for cleaning filter -Y2.2
3	Pilot valve for pulsed instrument air -Y1.1
4	Diaphragm valve for pulsed instrument air -Y1.2
5	Connection for instrument air (max. 6 bar) bulkhead fitting 12 mm
6	Connection for test gas bulkhead fitting 6 mm
7	Connection for control air (max. 6 bar) bulkhead fitting 6 mm
8	Connection for Pt100
9	Heated sample gas line
10	Power supply
11	Heated cutoff valve -Y5 (option)
12	Solenoid valve for venting -Y4
13	Diaphragm valve for cleaning filter surface and probe tube -Y3.2
14	Pilot valve for cleaning filter surface and probe tube -Y3.1
15	Protective case for the probe
16	Terminal box
17	Filter unit
18	Check valve
A	Connection for back-purging filter G½ to 12 mm pipe coupling
B	Connection for back-purging filter surface and probe tube G½ to 12 mm pipe coupling
C	Sample gas outlet G¼ to 6 mm pipe coupling
D	Test gas connection G¼ to 6 mm pipe coupling

Probe tube type 40

L1 = length of the probe tube (dimensions in mm)

L1 = 500/1000/1500/2000/2500 mm

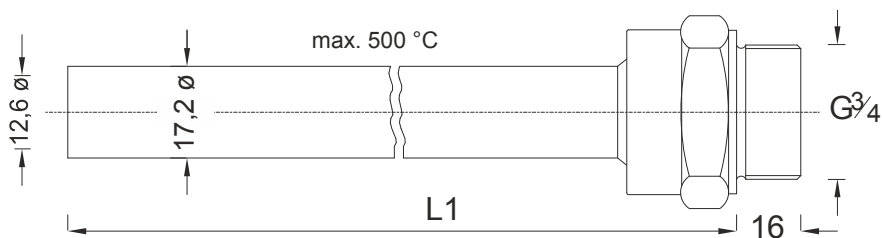

Probe tube type 42

(dimensions in mm)

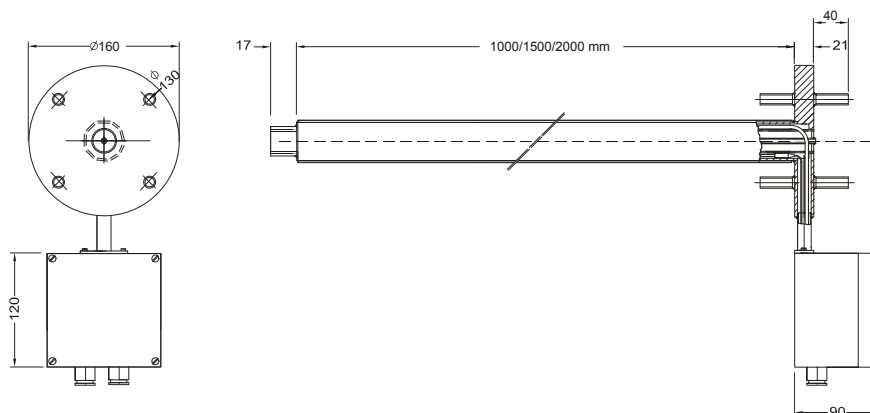

- If the PFE2 filter unit with standard protective box (450 x 450 x 400mm) is mounted to the heated, probe tube type 42, the electrical connections on the probe tube must be connected to the terminal box of the filter unit; in this case, the small terminal box, which is part of the heated probe tube, is not required.
- It must be ensured that the sample gas in the gland base, which is installed between the type 42 heated probe tube and the PFE2 filter unit, does not fall below operating temperature. The same applies for the wall tube with assembly flange. Insulation and, where necessary, heat tracing is required for this purpose.

Installing the sample gas line

Installing the sample gas line

- Observe the "Piping diagram" in the system documentation.
- Connect the sample gas line to the gas sampling probe.

NOTICE

Neither grease or lubricant may be used during installation of the sample gas line. This can falsify the measured values.

- The sample gas line from the gas sampling probe to the analyzer cabinet must be inclined and run as close as possible in a separate channel. Water pockets must not be allowed to form, especially at the sampling point.
- The sample gas line must be laid so as to avoid sharp bends, kinks and the crossing of other lines. The minimum bending radius is 200 mm.
- The heated sample gas line
 - must never be laid through walls if there is a possibility of subsequent sealing by means of sealing compounds, since this may damage the sample gas line;
 - must not be laid in a cable channel;

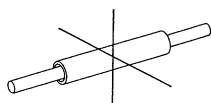

- must not be laid near other gas or power lines in a cable grid. This applies in particular for closed cable grids.

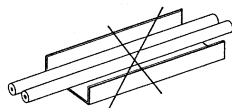

- Assemble the heated sample gas lines on freely-laid C-profiles using a counterpart. Do not over-tighten.

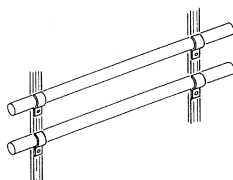

- Insert the sample gas line through the opening in the right-hand cabinet wall.

CAUTION!

Do not connect the sample gas line to the sample gas inlet on the ASP block yet! This connection is made by ABB personnel during the commissioning procedure.

First connect a PTFE tube of approx. 0.5 m in length to the sample gas inlet **2** on the ASP block. Ambient air will then be sucked into the analyzer cabinet from outside once the FTIR spectrometer is powered up.

The inlet for the water steam generator **1** on the ASP block must be closed by means of a blanking plug.



1 Inlet for the water vapor generator

2 Pressure sensor

- Connect the electrical leads on the sample gas line as per the "Wiring diagram" and "Terminal diagram" in the system documentation.

Installing the operating gases

Installing the instrument air supply

- Observe the "Requirements for the instrument air supply" (see page 23).
- Provide the material required for the installation (see page 29).
- Observe the "Piping diagram" in the system documentation.
- Connect the instrument air feed line to the bulkhead fitting in the right-hand cabinet wall.
- Install a locking device in the instrument air feed line with a manometer $p_e = 5.5$ to 7 bar.

Installing the test gas cylinders

- Observe the "Piping diagram" in the system documentation.
- Fit the test gas cylinders with pressure reducers and install in the proximity of the analyzer cabinet. Short test gas lines translate into short dead times.
- Observe the national regulations for the operation of pressure tanks and the permissible ambient temperatures and the labels on the pressure reducers.

Gas line connection

- Provide the material required for the installation (see page 29).
- Observe the "Piping diagram" in the system documentation.
- Ensure that the gas pipes are connected to the gas connections provided for this purpose and are not interchanged! After connecting the gas lines, the correct assignment to the gas connections should be checked by a second person.
- Ensure the utmost cleanliness when connecting the gas lines! Gas inlets, outlets, fittings, hoses and pipes must be free of dust and grease.
- If there is a risk of frost, heat the gas lines.
- The gas connections (bulkhead fittings) are located in the right-hand cabinet wall. Hold back the bulkhead fittings when connecting the gas lines!

Combustion gas for the FID

- Connect two-stage cylinder pressure reducer with flow restrictor (version for high purity gases) to the combustion gas cylinder.
- Connect combustion gas line to the bulkhead fitting provided. For safety reasons (see page 9) a flow restrictor, which limits the combustion gas flow to 10 l/h, is integrated into this bulkhead fitting.

WARNING

This bulkhead fitting is a safety-relevant component. It may be replaced only by certified service personnel!

- If the analyzer system is equipped with the option “Hydrogen monitoring of the analyzer cabinet” (see page 16) connect the combustion gas line to the inlet of the H₂ safety valve. The outlet of this valve is connected ex-works to the bulkhead fitting with integrated flow restrictor.
- Check the seal integrity of the combustion gas line: Set the high-pressure stage of the pressure reducer of the combustion gas cylinder to $p_e = 1200 \pm 100$ hPa (1.2 ± 0.1 bar) and purge the combustion gas line. Using a hydrogen leak detector (measuring principle: thermal conductivity) to check the seal integrity of the combustion gas line. Close the combustion gas cylinder.

Waste gas

- Connect the gas discharge line (shortest possible line with largest possible internal diameter). Allow waste gas to discharge freely; do not install restrictions or shut-off fittings. The internal diameter of the gas discharge line must be expanded as close behind the analyzer cabinet as possible, in order to prevent dynamic air pressure on account of excessive line length.
- Ensure air and condensate are separated after discharge. According to the gas transport principle, the sample gas is diluted in a ratio of approx. 1:5 after being measured in the instrument air. Nonetheless, condensation can occur when the dew point of the water in the mixture has reached ambient temperature.

CAUTION!

The exhaust gas line on the measuring gas output needs to be laid in a falling manner in any event. Otherwise, there is a danger that condensate forms with corrosive components, which may result in leaks.

Purging gas for gas extraction probe

- Connect the purge gas line to the gas sampling probe (for emergency purging and feeding test gas to the probe). The purge gas line can be laid on the same tray as the sample gas line.

Compressed air supply for back-purging the gas extraction probe (option)

- Connect compressed air for cleaning the sampling filter and the probe tube (back-purging option) to the corresponding connections on the probe's protective box.

Connecting the electrical leads

Description of the signal inputs and outputs

- Analog outputs: 4 to 20 mA, joint minus pin, electrically isolated, randomly groundable, max. DC 30 V, load max. 600 Ω , resolution 16 bit
 - Analog inputs: 4 to 20 mA, joint minus pin, electrically isolated against mass, max. DC 30 V, $R_i = 41.2 \Omega$, $R_u = 100 \text{ k}\Omega$, resolution 16 bit
- NOTICE:** When not all channels are connected in an analog output or analog input module the status LED lights red also in normal operation.
Recommendation: Short-circuit unused channels with a jumper wire.
- Digital relay outputs: potential-free contacts (powerless status opened, fail safe), max. AC/DC 277 V, max. current AC1 5 A, max. current per group of 4 AC1 20 A
 - Digital inputs: Optoelectronic coupler with internal power supply DC 24 V, switched potential-free contacts, status 0: $U_L < \text{DC } 5 \text{ V}$, status 1: $U_H > \text{DC } 11 \text{ V}$, $I_H \text{ min / max} = 2 \text{ mA} / 4.5 \text{ mA}$
 - PROFIBUS: One 9-pole sub-D plug each for PROFIBUS IN and PROFIBUS OUT or one 5-pole M12 panel feed-through each for PROFIBUS IN and PROFIBUS OUT

PROFIBUS IN:

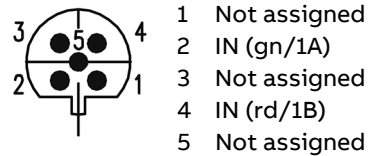

PROFIBUS OUT:

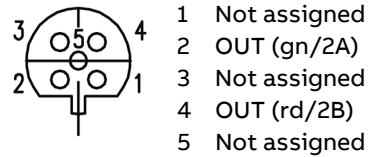

NOTICE: If the ACF5000 is installed at the end of a PROFIBUS network, the load resistor on the PROFIBUS plug, which is on the bottom of the system controller housing on the inside of the cabinet door, must be switched to ON.

- Modbus: 9-pole sub-D plug or 5-pole M12 panel feed-through

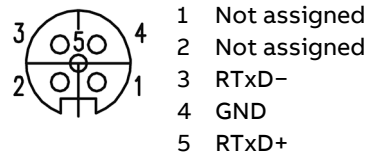

- Ethernet: RJ45 female connector or 8-pole M12 panel feed-through

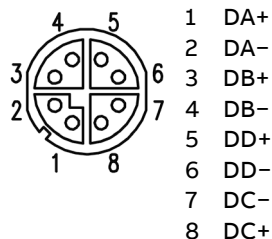

Connecting the electrical leads

- Provide the material required for the installation (see page 29).
- Observe "Arrangement diagram", "Wiring diagram" and "Terminal diagram" in the system documentation.
- The cable glands for the electrical leads are located in the right-hand cabinet wall.
- When laying the electrical leads, observe the relevant national safety regulations for installing and operating electrical systems.

Connecting the signal lines

- Lay the signal lines separately from the power supply lines.
- Lay analog and digital signal lines separately from each other.
- Carefully plan the combination of signal lines in cables, including for the purpose of feeding through the cable glands.
- Connect signal lines to the terminal blocks on the I/O modules at the rear wall.
- Lay the screen of the screened cable in accordance with the local regulations. In doing so, consider the potential differences and interspersions of interference signals.

Connect power supply

⚠ CAUTION

High leakage current: 9 mA!

- Observe the "Requirements for the power supply" (see page 25).
- Before connecting the power supply, make sure that the operating voltage set on the analyzer system matches the mains voltage.
- The protective ground conductor must be attached to a protective conductor terminal before any other connections are made. The analyzer system is potentially hazardous if the protective ground conductor is interrupted inside or outside the analyzer system or the protective conductor terminal is unmade.
- Connect the power supply to the terminal strips -X80 or -X90 (USV).
- Connect the power supply lines to the heated collection assemblies (where applicable in temperature-resistant design) on the terminal strips -X81, -X91 and, where applicable, on the corresponding line protection switches.
- Connect the connection leads to the Pt100 resistance thermometers of the external, heated sampling assemblies to the interface module -X82 on the right side wall.
- Option "Hydrogen monitoring of the analyzer cabinet" (see page 16): Connect the power supply lines of the gas warning central, the contactors and the H₂ safety valve.

Commissioning

Recommissioning

Initial commissioning

The analyzer system is essentially commissioned by the authorized personnel of the manufacturer or of the supplier.

NOTICE

The initial commissioning of the option "Hydrogen monitoring of the analyzer cabinet" may only be performed by certified personnel of the manufacturer of the gas warning central and the gas sensor.

Recommissioning

To restart the analyzer system from cold, after a prolonged shutdown for example, proceed as follows.

Procedure

- 1 **IMPORTANT!** Connect instrument air and purge the analyzer system for 30 minutes before opening the analyzer cabinet door and powering up the analyzer system.
- 2 Open analyzer cabinet door.
 - 1 Check pre-pressure and, where applicable set to $p_e = 5.5$ to 7 bar.
 - 2 Check pressures and flows on the pneumatic plate on the right-hand cabinet internal wall against the values in section "Operating gases and test gases" (see page 23).

CAUTION! The hydrogen supply must remain switched off!
NOTICE: The purge line between the analyzer system and gas sampling probe must be laid.
- 3 Power supply power-up
 - 1 Make sure that all circuit breakers are deactivated.
 - 2 Turn on the main switch.
 - 3 Activate the circuit breaker for the FTIR spectrometer.
- 4 Activate all other circuit breakers.
- 5 The analyzer system starts to heat up automatically.
 - The assemblies in the analyzer cabinet reach their target temperatures after approx. 2 hours. The gas sampling probe reaches its target temperature after 3 to 4 hours.
 - The gas extraction begins as soon as the temperatures of the FTIR cell and ASP block reach 150°C.
 - The sample gas input and output pressures should adjust automatically to SGI = 850 hPa and SGO = 750 hPa.
Failure to reach these pressure values indicates a leak in the analyzer system.
- 6 Connect the sample gas line to the gas sampling probe.
- 7 Have a complete seal integrity test carried out by certified and authorized personnel.
- 8 Turn on the hydrogen supply and restart the FID (see below).

Start of the measurement

On a restart, the analyzers start to measure automatically:

- the oxygen sensor within a few minutes of the circuit breakers being activated;
- the FTIR spectrometer within 5 to 10 minutes of the circuit breakers being activated (the LEDs Power and Status illuminate green);
- the FID on successful completion of the start sequence.

FID restart

Heating-up phase, connect supply gases

- 1 Select the Controller measured values menu item:
MENU → Diagnosis/Information → Module-specific → Controller measured values
 In this menu item, the position values of the temperature controllers are displayed, among other things:
 T-Re . D Temperature of the ASP block
 T-Re . E Temperature of the FTIR cell
 T-Re . IP Temperature of the instrument air pre-heating
 TR . VV1 Temperature of the pre-amplifier
 The temperature values increase slowly after activating the power supply.
- 2 Connect instrument air, combustion air and combustion gas. Adjust the pressure to the value specified in the Analyzer Data Sheet with the corresponding external pressure regulator.
- 3 The controlled variables of the internal pressure regulator are also displayed in the Controller measured values menu item; the pressures of the supply gases are set by means of the controlled variables:
 SGI Pressure on the measured gas nozzle
 SG0 Pressure in the combustion chamber (output)
 C-air Combustion air
 C-gas Combustion gas
 Random values can initially be displayed for the position values. The values are updated for the first time approx. 10 s after selecting the menu option and then approx. every 10 s. The pressure control is in progress in the background. It may take some time to set the pressures depending on the setting of the inlet pressure.
 The analyzer system automatically reverts to the measurement mode to display measured values if the operator has not pressed a key in menu mode in the last five minutes.
- 4 During the heating phase, the following status messages are displayed:
 "Operating temperature": The temperature of the detector has not yet reached the threshold.
 "Flame error": The flame has not yet ignited.
 "Temperature limit value 1, 2": The temperature of the ASP block (T-Re . D) and possibly of the FTIR cell (T-Re . E) is above or below the upper or lower limit value 1 (2).
 "Pressure limit value 1, 2": The pressure at one of the internal pressure regulators for instrument air (input, output), combustion air (air) or combustion gas (H₂) is above or below the upper or lower limit value 1 (2).
- 5 As soon as the temperature of the detector reaches the threshold value (150°C), the corresponding solenoid valve in the FID automatically switches off the instrument air. The negative pressure regulation and the combustion air regulation attempt to adjust the pressures to the respective set point.
 The sample gas begins to flow through the FID after the instrument air is connected.

- 6 After the pressures have been adjusted to the respective set point, the respective solenoid valve in the FID automatically connects the combustion gas. The combustion gas regulation attempts to adjust the pressure to the set point.

Flame ignition

- 7 Flame ignition is automatic.

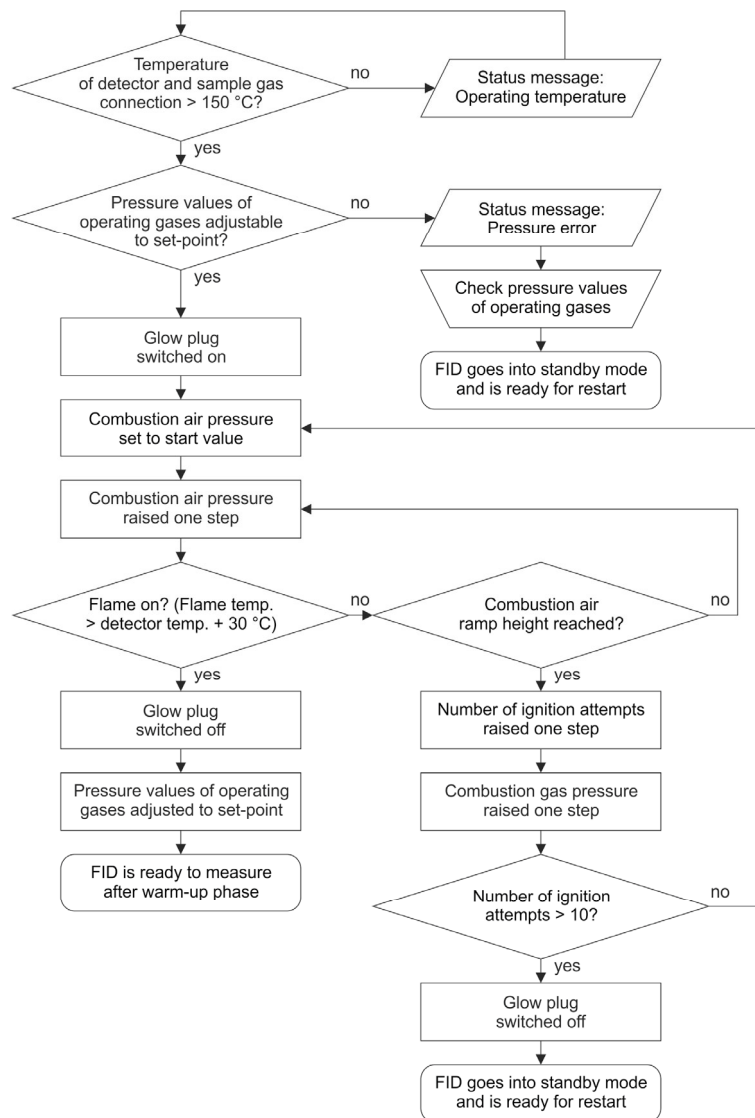

Depending on the number of ignition attempts, flame ignition can take up to 10 minutes.

On initial commissioning of the FID, it may occur that, depending on the position of the combustion gas line, there is not sufficient combustion gas available to ignite the flame at first. In this event, the ignition of the flame needs to be restarted in the Standby/Restart FID menu. The temperature of the flame is displayed in the Raw measurement values auxiliary values menu in the Flame parameter. The flame is considered to be "on" when the flame temperature is at least 30°C higher than the detector temperature.

With the ignition of the flame, the actual commissioning of the FID is ended.

CAUTION!

The analyzer cabinet door must always kept closed during operation!

Maintenance

General notices

NOTICE

Only persons familiar with the maintenance of comparable analyzer systems and who possess the qualification required for such work are allowed to work on the analyzer system.

 WARNING

The following must be observed during all maintenance work:

- The general safety instructions (see page 6),
 - The safety instructions for handling the analyzer system (see page 8),
 - The safety instructions for handling the analyzer system with integrated FID analyzer (see page 9),
 - The safety instructions for handling the FTIR spectrometer (see page 10),
 - The safety instructions for working with poisonous gases (see page 11).
-

Visual inspection

Internal view of the analyzer cabinet

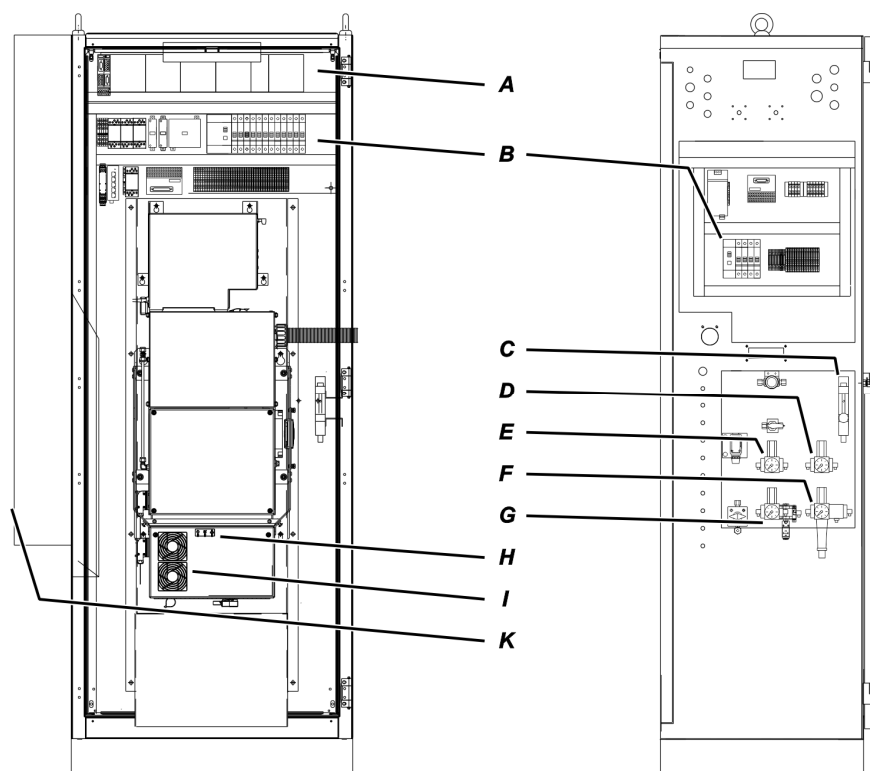

Visual inspection

External instrument air regulator		5.5 to 7 bar
External gas cylinder pressure reducers:		
Zero gas, O ₂ analyzer (3 vol. % O ₂ in N ₂)		1.5 ± 0.1 bar
Combustion gas, VOC analyzer (H ₂)		1.2 ± 0.1 bar
Zero gas, VOC analyzer (N ₂ or zero gas O ₂ analyzer)		1.5 ± 0.1 bar
Span gas, VOC analyzer (propane in N ₂)		1.5 ± 0.1 bar
A Status LEDs of the analog and digital output modules		Green ¹⁾
B Circuit breakers and ground fault circuit interrupters activated		ON
C Purge gas flowmeter		125 l/h
D Instrument air pressure regulator, combustion air, VOC analyzer (-J86)		1.2 ± 0.1 bar
E Instrument air pressure regulator, purge air, spectrometer (-J88)		2.0 ± 0.1 bar
F Instrument air regulator with filter (-J85)		5.5 bar
G Instrument air pressure regulator, injector air (-J96)		4.5 ± 0.1 bar
H Status LEDs on the cover of the FTIR E-Box	"Power"	Green
	"Status"	Green
	"Network"	Orange/Green flashing
I Filter mattes on the cover of the FTIR E-Box		White
K Cooling unit display		Actual temperature value (target: 25°C)
Filter mattes in cabinet fan and exit filter		White

1) When not all channels are connected in an analog output or analog input module the status LED lights red also in normal operation.

Seal integrity test

CAUTION!

Do not use any leak search spray or similar leak search tools in the under-pressure area of the analyzer system. These media may result in damage to the analyzer system in the event of a leak.

Complete seal integrity test of the analyzer system

Complete seal integrity tests of the analyzer system are reserved for certified service personnel.

It should be carried out regularly during each maintenance work, at least every 12 months.

They must be performed after gas paths within the analyzer system have been opened and following a restart from cold.

Simplified seal integrity test of the sample gas path

NOTICE

The simplified seal integrity test is not suitable for testing the overall analyzer system for seal integrity. Therefore, it cannot replace the regular complete seal integrity test in particular (see above).

When must the simplified seal integrity test be performed?

A simplified seal integrity test must be performed in the following cases:

- Following work on the gas sampling probe (e.g. filter replacement),
- following replacement of the sample gas line,
- following replacement of the sample gas filter in the ASP block.

The simplified seal integrity test serves to check the seal integrity of the analyzer system, from the gas sampling probe to the ASP block.

Simplified seal integrity test via oxygen measurement

This method is based on connecting oxygen and observing the oxygen measured value.

- 1 Feed-in nitrogen, either locally or via the gas sampling probe.
- 2 Observe the oxygen measured value. After a running-in time of approx. 5 minutes with local feed-in or 20 minutes with feed in via the gas sampling probe, the oxygen measured value should drop to approx. 0.08%.
- 3 Failure to do so indicates a leak in the selected gas path (see Piping diagram in the system documentation).

Simplified seal integrity test via FID

This method can be employed only if an FID is built into the analyzer system. It is based on allowing hydrocarbon to act on any leaking points in the sample gas path and observing the measured value on the FID at the same time. A commercially available felt pen is used as a punctiform "Hydrocarbon source" for this purpose.

- 1 Starting at the sample gas sampling probe and working towards the analyzer cabinet, hold the felt pen for a few seconds close to each fitting, connection and screw.
- 2 Observe the FID measured value. In the presence of a leak, the measured value rises and drops back to the normal value relatively quickly. Due to the calibration times, the measured value can rise after a delay; after each "contact" with the felt pen, wait at least 2 minutes for a possible reaction.
- 3 Open the cover of the ASP block and hold the felt pen for a few seconds close to the sample gas line connection at the ASP block.

CAUTION

The ASP block is hot (approx. 180°C)!

Wear suitable protective gloves and safety goggles!

Other indications of leaks

The following states can indicate a leak in the analyzer system:

- The SGI and SGO pressures to be regulated by the analyzer system are no longer reached.
- The controlled variables for the SGI and SGO pressures in control mode are too great (> 90).
The position variables can be found in the menu under
Diagnosis/Information → Module-specific →
Controller measured values → FID.
- The measured oxygen concentration is much higher than the expected values.

This is only a possible indication of a leak. The absence of the states mentioned must not be used to conclude that the analyzer system is tight.

FID: Seal integrity and functional checks

CAUTION!

The seal integrity and functional checks described in this section may be carried out by qualified and specially trained persons only. If these conditions are not provided or the prescribed materials are not available, seal integrity and functional checks must be carried out by ABB service.

Seal integrity check of the combustion gas path

The seal integrity of the combustion gas line within the analyzer system must be checked regularly during each maintenance work and at least every 12 months using a hydrogen leak detector (leak rate $< 2 \times 10^{-4}$ hPa l /s). Do not use leak detector spray!

Seal integrity check of the combustion gas supply line

The seal integrity of the combustion gas feed line must be regularly checked in accordance with the two following instructions, depending on whether the combustion gas is offered from a bottle or a central supply.

Combustion gas from a bottle

- 1 Switch off the analyzer system power supply. Ensure that the shut-off valve in the combustion gas supply line is open.
- 2 Set the combustion gas pressure at approx. 1.4 bar.
- 3 Mark bottle pressure display on the high-pressure manometer.
- 4 Close the valve of the combustion gas bottle.
- 5 Observe the display on the high-pressure manometer – it should not change measurably in 10 minutes.
A measurable change in the display is an indication of a leak in the combustion gas path between the combustion gas bottle and the combustion gas inlet valve of the analyzer system. In this case the following measures are to be taken:
 - 1 Check the pressure reducer and the combustion gas line between the bottle and analyzer system with a leak detection spray. A leak in this area must be remedied and another leak test must be performed before the analyzer system is put into operation again.
 - 2 If no leak is found at the pressure reducer and in the combustion gas line, that means the analyzer system combustion gas inlet valve is leaking. **In this case, the analyzer system may not be put into operation!** The combustion gas inlet valve must be replaced by ABB service.
- 6 After conclusion of the seal integrity test, set the combustion gas pressure to 1.2 bar.

Combustion gas supply from a central supply

- 1 Switch off the analyzer system power supply. Ensure that the shut-off fitting in the combustion gas supply line is open.
- 2 Set the combustion gas pressure at approx. 1.4 bar.
- 3 Mark pressure indication on the manometer of the pressure reducer.
- 4 Shut off the combustion gas supply.
- 5 Observe the display on the manometer – it should not change measurably in 10 minutes.
A measurable change in the display is an indication of a leak in the combustion gas path between the pressure reducer and the combustion gas inlet valve of the analyzer system. In this case the following measures are to be taken:
 - 1 Check the combustion gas line between the pressure reducer and analyzer system with a leak detection spray. A leak in this area must be remedied and another leak test must be performed before the analyzer system is put into operation again.
 - 2 If no leak is found in the combustion gas line, that means the analyzer system combustion gas inlet valve is leaking. **In this case, the analyzer system may not be put into operation!** The combustion gas inlet valve must be replaced by ABB service.
- 6 After conclusion of the seal integrity test, set the combustion gas pressure to 1.2 bar.

Function test of the H₂ safety valve

Part of the option "Hydrogen monitoring of the analyzer cabinet" (see page 16) is a solenoid valve which is mounted on the outside of the right side wall of the analyzer cabinet and which interrupts the hydrogen supply to the analyzer system if the power supply fails or at 40 % LEL (H₂ safety valve).

The function of this H₂ safety valve must be checked with a sensitive hydrogen leak detector at every maintenance, but at least every 12 months.

Procedure

- 1 Switch off the power supply to the analyzer system.
- 2 Switch off the 24 V supply to the H₂ safety valve: The valve closes.
- 3 Shut off the hydrogen supply (from a central supply or from a bottle).
- 4 Disconnect the hydrogen supply line from the inlet of the H₂ safety valve. Wait a few minutes until the residual hydrogen has evaporated from the – now open – line.
- 5 Use the leak detector (highest sensitivity) to sniff the inlet of the H₂ safety valve.
 - If the leak detector indicates a hydrogen leak, this is an indication that the H₂ safety valve is not closing reliably. **In this case, the analyzer system must not be put back into operation!** The H₂ safety valve must be replaced by ABB service.
 - If the leak detector does not indicate a hydrogen leak, the analyzer system can be put back into operation:
- 6 Connect the hydrogen supply line to the inlet of the H₂ safety valve.
- 7 Open the hydrogen supply.
- 8 Switch on the 24 V supply to the H₂ safety valve: The valve opens.
- 9 Switch on the power supply of the analyzer system and put the FID back into operation (see page 46).
- 10 After a few minutes, sniff out the screwed connection of the hydrogen supply line at the inlet of the H₂ safety valve with the leak detector again.

Dynamic QR code

Application

Dynamic QR Code is a unique feature to display dynamically generated QR codes on the gas analyzer screen.

The QR code contains static information for device identification as well as dynamically generated information on system configuration and gas analyzer health status .

Static data for device identification are among other data:

- Production number
- Production date
- Software version
- Serial numbers of built-in analyzer modules and components

Dynamic data for error diagnosis are among other data:

- Status messages
- Measured values
- Temperature, pressure and flow values
- Drift values
- Analyzer-specific values

In combination with mobile devices (smartphone, tablet, etc.) Dynamic QR Code represents an innovative way of customer's communication which allows, for instance, improved case-specific support by ABB resulting in an increased availability of analyzer assets.

Dynamic QR Code is compatible with the ABB application "my Installed Base" as well as with standard QR code scanner applications.

Handling

The QR code is selected in the gas analyzer's diagnosis menu and displayed on the gas analyzer's screen.

There is a direct link from the status messages overview to the diagnosis menu. In addition, the QR code can be selected in Remote HMI and scanned from the computer screen.

The displayed QR code is scanned using the QR code scanner application installed in the mobile device. The resulting text information displayed on the mobile device's screen is then sent by e-mail or a suitable messenger service to the local service representative defined in the "Measurement Care" agreement.

As an alternative, a photo of the displayed QR code can be sent to the service representative.

Select QR code

Menu path

Menu → **Diagnosis/Info.** → **QR Code Display**

Procedure

- 1 Select system overview or specific analyzer module.
- 2 Select QR code with **ENTER**.
- 3 Scan QR code.
- 4 Return to selection with **Back**.

The diagnosis menu can be selected directly from the status messages overview.

The QR code can also be selected in Remote HMI and scanned from the computer screen.

Recommended QR code scanner applications

ABB recommends the use of the following QR code scanner applications (available free of charge for iOS and Android):

"my Installed Base" by ABB

Download in App Store:



Download in Google Play:



"QR Scanner" by Kaspersky

Download in App Store:



Download in Google Play:



Notify service

Who should you contact for further help?

Please contact your local service representative. For emergencies, please contact

ABB Service,

Telephone: +49-(0)180-5-222 580, Fax: +49-(0)621-381 931 29031,

E-mail: automation.service@de.abb.com

Before you notify service...

Before you notify service because of a malfunction or a status message, please check whether there actually is an error and whether the analyzer system is actually operating out of specifications.

When you notify service...

When you notify service because of a malfunction or a status message, have the following information available:

- the production number (F-No.) of the analyzer system, you can find it on the type plate and in the Analyzer Data Sheet,
- The system controller and system module software versions are found in the menu item
MENU → Diagnosis/Information → System overview,
- An exact description of the problem or status as well as the status message text or number.

This information will enable the service personnel to help you quickly.

Have the Analyzer Data Sheet ready – it contains important information that will help the service personnel to find the cause of the malfunction.

When you return the analyzer system to the service department...

CAUTION!

When you return the analyzer system to the service department, e.g. for repair, please state which gases have been supplied to the analyzer system. This information is needed so that service personnel can take any requisite safety precautions for harmful gases.

Decommissioning

Shutting down the analyzer system

Shutting down the analyzer system temporarily

- 1 Switch the gas flow control on zero gas probe (zero air connection via the probe) in order to interrupt the measured gas supply.
- 2 Wait until all measured values match the values of the cleaned zero air from the air treatment station.
- 3 Disconnect the sample gas line from the gas sampling probe and seal the probe connection with a blind fitting.
- 4 Switch the gas flow control to "Zero gas local" (zero air supply local).
- 5 FID (option): Shut off the combustion gas feed.
- 6 Switch off the power supply to the individual assemblies and finally turn off the main switch on the right-hand side of the cabinet wall; with UPS, turn off the two main switches.
- 7 Shut off the instrument air supply to the analyzer system.

Packing the analyzer cabinet

Packing the analyzer cabinet

- 1 Vacuum-pack the analyzer cabinet in film.
- 2 Lay out desiccant in the transport crate. Use an amount of desiccant that is appropriate for the packing volume and the expected transport time (min. 3 months).
- 3 Place the analyzer cabinet into the transport crate on snubbers and chock.
- 4 Mark the transport crate as specified (in particular as "Fragile product").

NOTICE

- Moisture that could freeze at low storage and transportation temperatures must not remain in the analyzer system.
 - The analyzer cabinet and/or the FTIR spectrometer must be packed at a dry and heated location, preferably at the installation site.
 - Having the analyzer cabinet transported by a specialist company is highly recommended.
 - The analyzer cabinet must be transported on its rear in the horizontal position.
 - Ambient conditions during transport and storage:
Temperature -25 to +65°C, humidity ≤ 75%.
-

Disposal

Notes for disposal

Products that are marked with the adjacent symbol may not be disposed of as unsorted municipal waste (domestic waste). They should be disposed of through separate collection of electric and electronic devices.



This product and its packaging are manufactured from materials that can be recycled by specialist recycling companies.

Bear the following in mind when disposing of this product and its packaging:

- This product is under the open scope of the WEEE Directive 2012/19/EU and relevant national laws.
- The product must be supplied to a specialist recycling company. Do not use municipal waste collection points. These may be used for privately used products only in accordance with WEEE Directive 2012/19/EU.
- If there is no possibility to dispose of the old equipment properly, ABB service can take care of its pick-up and disposal for a fee. To find your local ABB service contact visit abb.com/contacts or call +49 180 5 222 580.

—
ABB Automation GmbH
Measurement & Analytics
Stierstädter Str. 5
60488 Frankfurt am Main
Germany
E-Mail: cga@de.abb.com

abb.de/analytical

—
We reserve the right to make technical changes or modify the contents of this document without prior notice. With regard to purchase orders, the agreed particulars shall prevail. ABB does not accept any responsibility whatsoever for potential errors or possible lack of information in this document.

We reserve all rights in this document and in the subject matter and illustrations contained therein. Any reproduction, disclosure to third parties or utilization of its contents – in whole or in parts – is forbidden without prior written consent of ABB.

© ABB 2018

3KXG141001R4401